



## Global "Heavy Lifter" Transport Aircraft "Dumbo"

Title	Global "Heavy Lifter" Transport Aircraft "Dumbo"
Item Type	Technical Report
Authors	Riester, Peter;Ellis, Colleen;Wagner, Michael;Orren, Scott;Smith, Byron;Skelly, Michael;Zraggen, Craig;Webber, Matt
URI	<a href="https://hdl.handle.net/10945/60154">https://hdl.handle.net/10945/60154</a> ; <a href="https://ntrs.nasa.gov/search.jsp?R=19940020433">https://ntrs.nasa.gov/search.jsp?R=19940020433</a>
Date Issued	1992-09
Rights	This publication is a work of the U.S. Government as defined in Title 17, United States Code, Section 101. Copyright protection is not available for this work in the United States.
Download date	2026-06-16 11:17:10
Link to Item	<a href="https://hdl.handle.net/10945/60154">https://hdl.handle.net/10945/60154</a>

**Downloaded from NPS Archive: Calhoun**

NASA-CR-195500

NASW-4435

# NAVAL POSTGRADUATE SCHOOL Monterey, California

IN-05-CR  
204253  
P-102



## Global "Heavy Lifter" Transport Aircraft "Dumbo"

by

Flying Circus Inc.

September 1992

Project Advisor:

Prof. C.F. Newberry

(NASA-CR-195500) DUMBO HEAVY  
LIFTER AIRCRAFT (Naval  
Postgraduate School) 102 p

N94-24915

Unclass

G3/05 0204253



AIAA GRADUATE DESIGN COMPETITION  
DUMBO HEAVY LIFTER AIRCRAFT  
FLYING CIRCUS DESIGN TEAM

Peter Riester

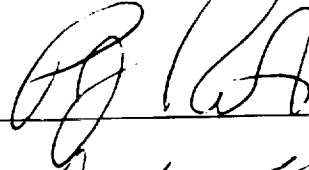

Colleen Ellis

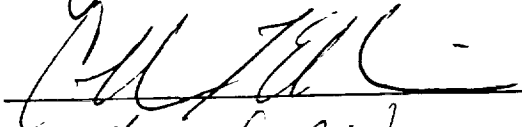

Michael Wagner

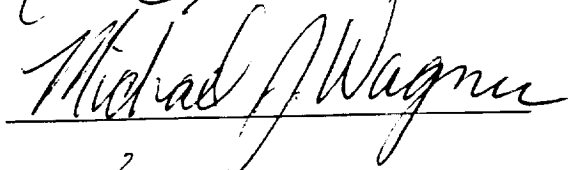

Scott Orren

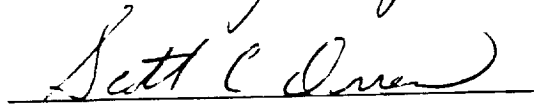

Byron Smith



Michael Skelly

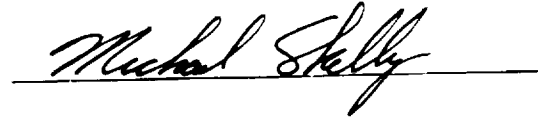

Craig Zraggen

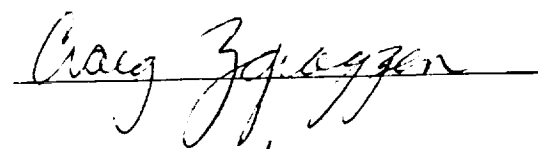

Matt Webber

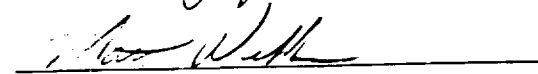

(All AIAA numbers pending)

Project Advisor: C.F. Newberry

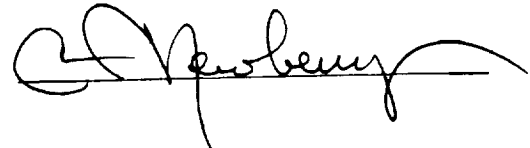

Faculty Advisor: M.F. Platzer



## TABLE OF CONTENTS

	page
I. INTRODUCTION.....	3
II. CONFIGURATION/WEIGHT.....	10
III. AERODYNAMICS.....	25
IV. PROPULSION.....	34
V. STRUCTURAL ANALYSIS.....	44
VI. PERFORMANCE.....	54
VII. STABILITY AND CONTROL.....	63
VIII. AIRCRAFT SYSTEMS.....	75
IX. PRODUCTION.....	87
X. COST AND QUALITY.....	91
XI. SUMMARY.....	98
REFERENCES.....	99

# I. INTRODUCTION

## A. BACKGROUND

The world is rapidly changing from one with two military superpowers, with which most countries were aligned, to one with many smaller military powers. In this environment, the United States cannot depend on the availability of operating bases from which to respond to crises requiring military intervention. Several studies (e.g. the SAB Global Reach, Global Power Study) have indicated an increased need to be able to rapidly transport large numbers of troops and equipment from the continental United States to potential trouble spots throughout the world. To this end, a Request for Proposals (RFP) for the concept design of a large aircraft capable of "projecting" a significant military force without reliance on surface transportation was developed. These design requirements are listed below.

- ~ Minimum payload (at 2.5 g maneuver load factor) of 400,000 pounds
- ~ Minimum unfueled range of 6,000 nautical miles
- ~ Aircraft must operate from existing domestic air bases and use existing airbases or sites of opportunity at the destination.

The mission profile outlined in the RFP is shown in Figure I-1. It encompasses the following:

1. Warm-up and taxi for 15 minutes
2. Takeoff and climb to best cruise altitude
3. Cruise at best altitude and Mach to midpoint

4. Descend on course and land
5. Taxi/idle for 30 minutes, off load full payload
6. Load 15% of full payload, takeoff and climb to best cruise altitude
7. Return at best cruise altitude and Mach
8. Loiter 15 minutes (15 minutes reserve fuel)
9. Descend, land and taxi 10 minutes

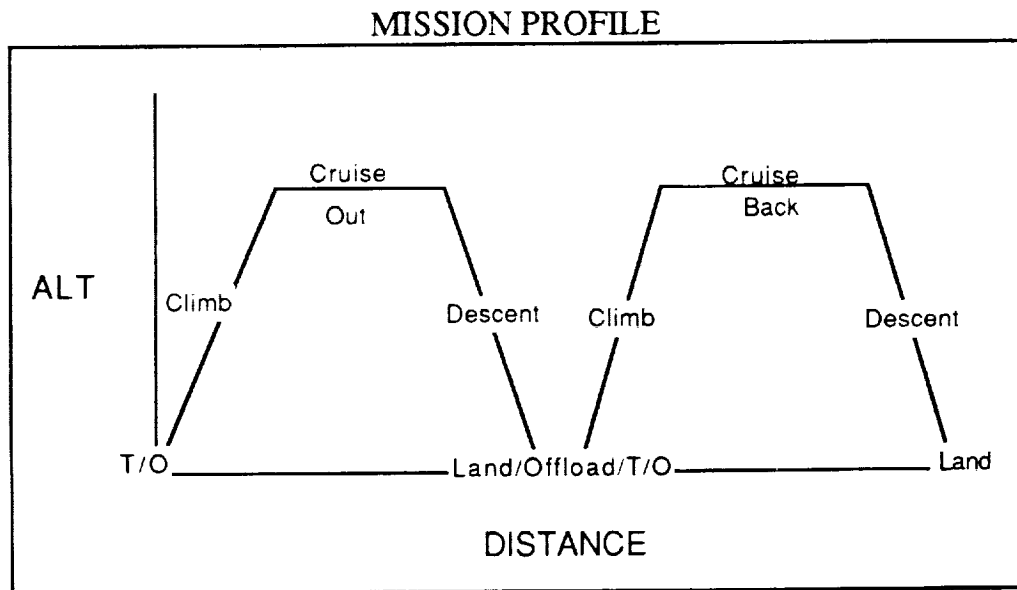

Figure I-1

This RFP was acquired after two thirds completion of a previously acquired, more aggressive and stringent RFP. The Flying Circus Design Team continued with the originally acquired RFP. In order to maximize the amount of material that can be transported in 72 hours of continuous operations by a fleet of global transports based in the United States flying to any location in the world, an aircraft capable of more than the minimum requirements of the RFP was necessary. To minimize the cost of delivery, a larger aircraft capable of

transporting twice the payload over twice the range specified in the RFP was desirable. These more aggressive design requirements are listed below:

- ~ Payload of 800,000 pounds (at 2.5g maneuver load factor) to include 6 M-1 tanks, 3 AH-1G helicopters, 20 standard pallets, and 200 troops
- ~ Cruise speed of .77 Mach at Best Cruise Altitude
- ~ Mission Radius:
  - Fly 6,500 nm with full payload, land and return 6,500 nm with 15% of full load, without refueling
- ~ Initial Airfield Critical Field Length of 10,000 feet at sea level, standard day
- ~ Midpoint Airfield Critical Field Length of 8,000 feet at 4,000 feet elevation, at 95 degrees Fahrenheit

## **B. FLYING CIRCUS DESIGN ORGANIZATION**

In response to these RFP requirements, a design team for this aircraft, named Dumbo, was formed at Flying Circus. On this design team, each engineer had a primary area of responsibility which included their respective area of expertise, as well as a secondary area of responsibility. The composition and organization of the Flying Circus design team, including each engineer's respective areas of responsibility, is shown in Figure I-2.

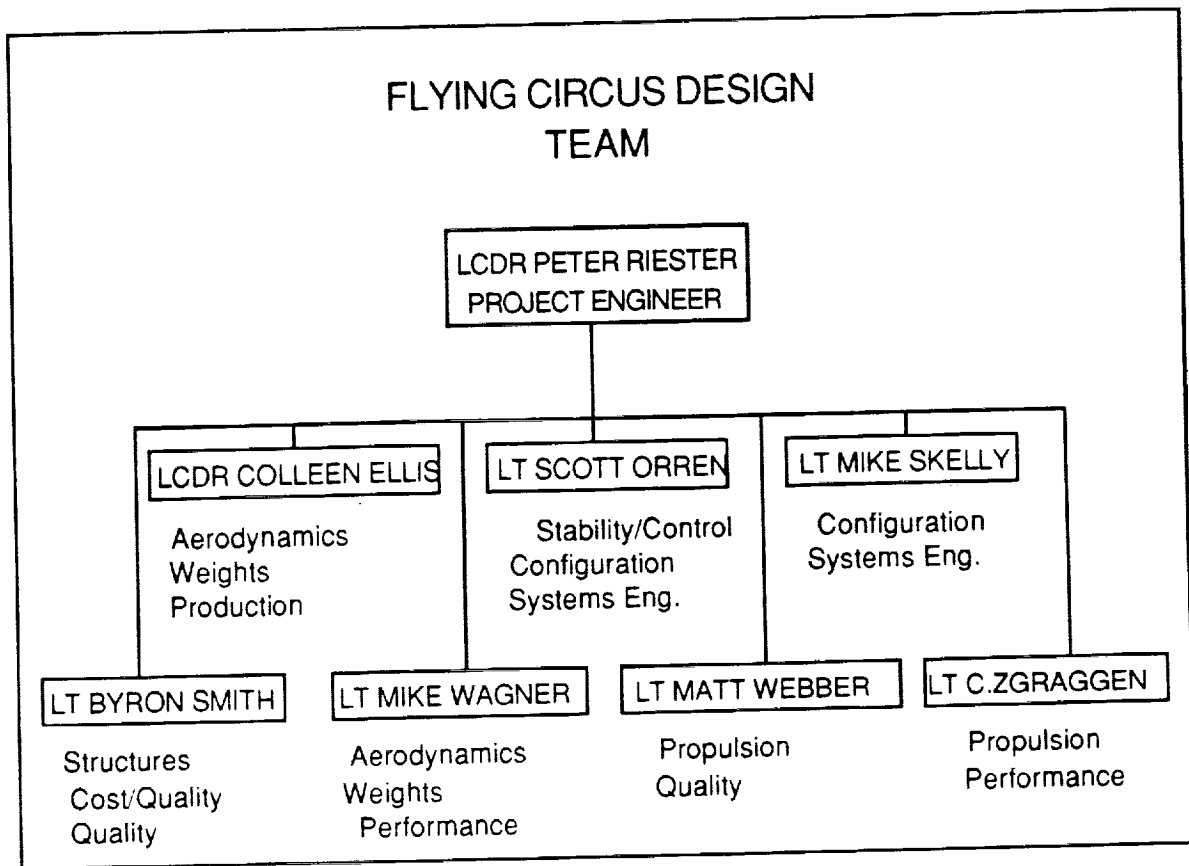

Figure I-2

### C. DESIGN GOALS

Prior to developing an initial design, the design team developed a philosophy upon which subsequent considerations would be based. This philosophy resulted in four design goals integral to the final conceptual design choice for the Dumbo aircraft. The first goal was to design Dumbo to maximize mission effectiveness. It is because of this first goal and the date of receipt of the latest RFP, that Dumbo's design exceeded all RFP requirements. The second goal was to make the design as simple as possible. A more complex design may have more performance capability, but at the expense of higher cost, additional support

equipment, and more complex operational and maintenance requirements, including additional training for both the aircrew and maintenance personnel. The third goal was to keep the total weight to an absolute minimum, given the aggressive range and payload requirements set by the Flying Circus Design Team. These goals increased the aircraft's payload and minimum fuel requirements to figures that are six times greater than any existing aircraft. Any non-essential weight addition beyond these self-imposed requirements would result in an exponential weight increase for the overall aircraft. This could easily result in an aircraft too large and heavy to land at any existing airfield. The fourth and final goal of the Flying Circus design team was to reduce "gold plating" to an absolute minimum, as past experience has shown that it seldom does little more than increase the cost and complexity of the final product.

#### **D. CONSTRAINT DIAGRAM**

In the earliest stages of the design process, the only characteristics of the aircraft that have been clearly defined are the requirements that are set forth in the RFP. These requirements were used to define specific aircraft characteristics including thrust-to-weight ratio (T/W) and wing loading (W/S) through the use of a constraint analysis diagram. The diagram plots various required performance characteristics of the aircraft as a function of thrust-to-weight (T/W) and wing loading (W/S). The diagram reveals a "solution space". It is within this solution space that a T/W--W/S combination can be chosen. A complete description of the constraint analysis diagram and the necessary performance equations can be found in Reference(28). It should be noted that the constraint analysis need not be limited to performance parameters.

Parameters such as maintainability and cost may be included if valid equations that are a function of T/W and W/S can be found.

In the case of the Dumbo aircraft, initial RFP requirements were limited. The result was that some assumptions had to be made. It was discovered that making initial assumptions posed no problems as long as frequent iterations of the constraint analysis was performed as more defined knowledge of the aircraft was acquired. The final iteration of the Dumbo aircraft's constraint analysis is shown in Figure I-3. Note that the plot shows a very wide and relatively flat-bottomed solution space. From initial assumptions, a W/S of 140 lb/ft<sup>2</sup> was chosen. This established a starting design point. Through further iterations, it was found that this wing loading corresponded to a T/W of approximately 0.21. Note also that a maintainability equation has been included. This equation is based on data from existing large military bombers and transports. The results from Figure I-3 were used as the starting point for the detailed conceptual design of the Dumbo aircraft, outlined in the following sections.

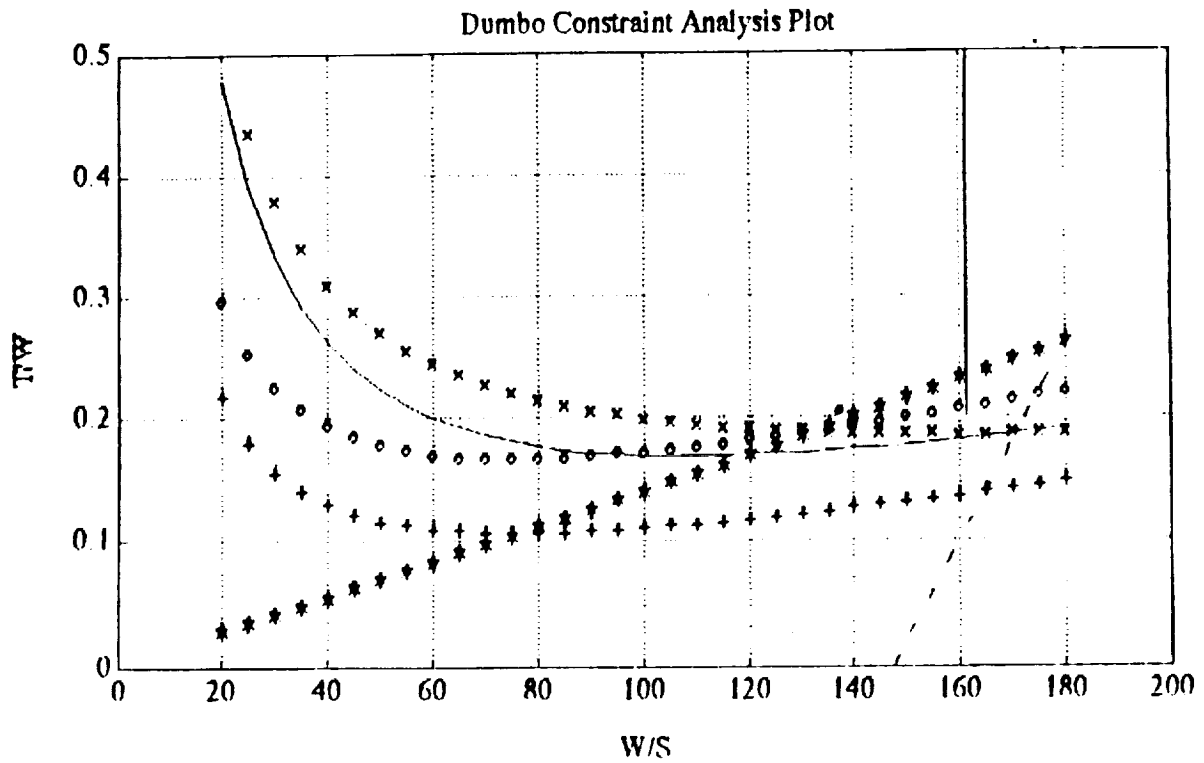

- KEY:
- 1) High Speed Cruise at  $M=0.77$  & 35k ft. ==> '—'
  - 2) Constant Speed Climb at  $M=0.51$  & 15k ft. ==> 'x x'
  - 3) Sustained 'g' Turn at 1.2g's & 20k ft. ==> '+ +'
  - 4) Level Accel Run at 30k ft. ==> 'o o'
  - 5) Takeoff Performance (Nicolai) ==> '\* \*'
  - 6) Landing Performance (Nicolai) ==> '|'
  - 7) Maintainability ( $M_{III}/FH=25$ ) ==> '—'

Figure I-3

## II. CONFIGURATION/WEIGHT

### A. BACKGROUND

The primary challenge in arriving at the Dumbo aircraft's configuration was meeting the 12,000 nautical mile range requirement at .77 Mach while providing the capacity to transport and air drop a large, heavy payload. The cruise Mach number dictated that the aircraft would have six large power plants and the range required a high L/D ratio, optimal fineness ratio and a minimum wetted area.

### B. ALTERNATIVES CONSIDERED

Prior to developing the initial design, the design team conducted an historical investigation into the various design considerations of heavy lifter aircraft previously developed. The aircraft considered included the Lockheed C-5 and several Boeing aircraft, particularly the 747. Although all previously built aircraft carried a payload significantly smaller than the one required by the design team's goals, basic aerodynamic requirements, such as high L/D, payload capability, minimum drag and thrust-to-weight ratios could be of help in the design of Dumbo. Specific features of these previous aircraft of interest to the design team included geometry, cruise speed, service ceiling, wing planform, gross weight, range and propulsion system. Out of this investigation, the alternatives given the most attention included :

- a large conventional aircraft
- a large canard aircraft
- a lambda wing/fuselage design
- a two wing aircraft
- a three wing aircraft

## 1. Lambda Wing

This design was inherently suitable for high speeds because of its highly swept wing. Initial cost and weight estimates placed it heavier and more expensive than the more conventional designs. Had the RFP required an aircraft significantly faster than the .77 Mach cruise, the lambda wing may have been the best configuration, Figure II-1.

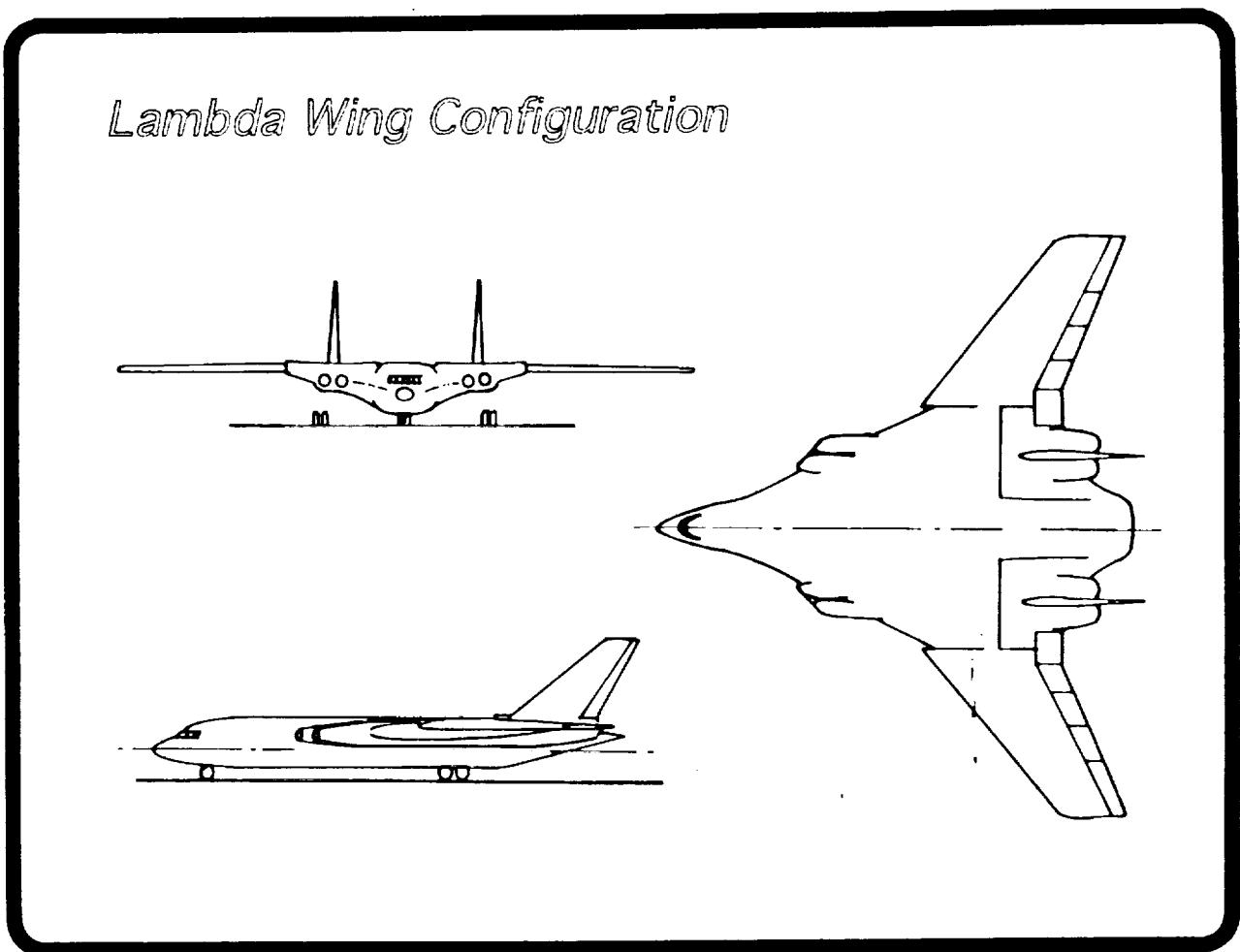

Figure II-1

## 2. Conventional High Wing/High Tail

Initial calculations gave this design the lowest CDo. This design's greatest drawback was its enormous wing span, in excess of 500 ft., which increased structural design problems and total aircraft weight, Figure II-2.

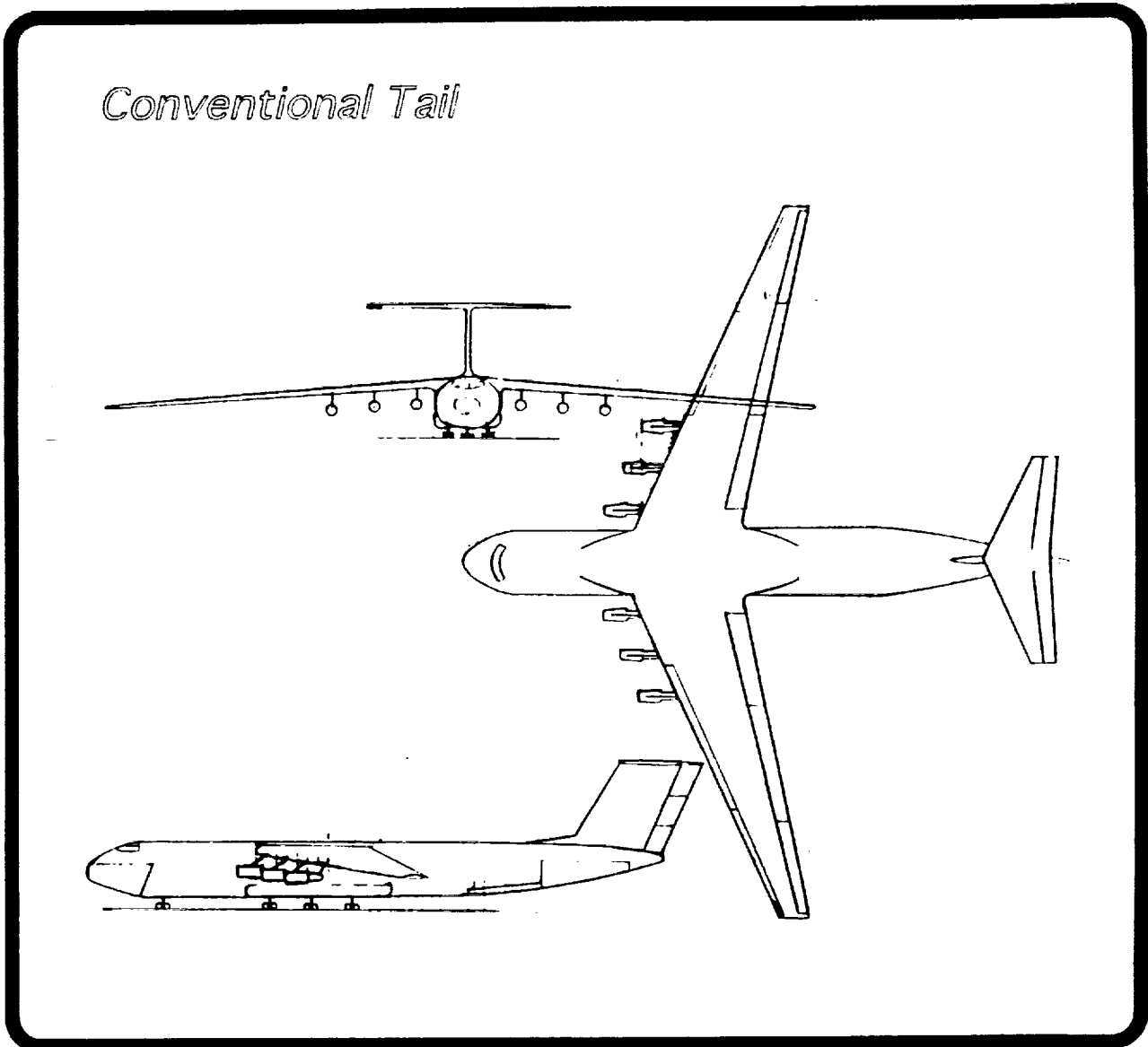

Figure II-2

### 3. Canard

Despite this design's advantage of a higher  $C_l$  max when compared to the conventional tail design, it still required the same wing span  $b$  of 500 ft, Figure II-3.

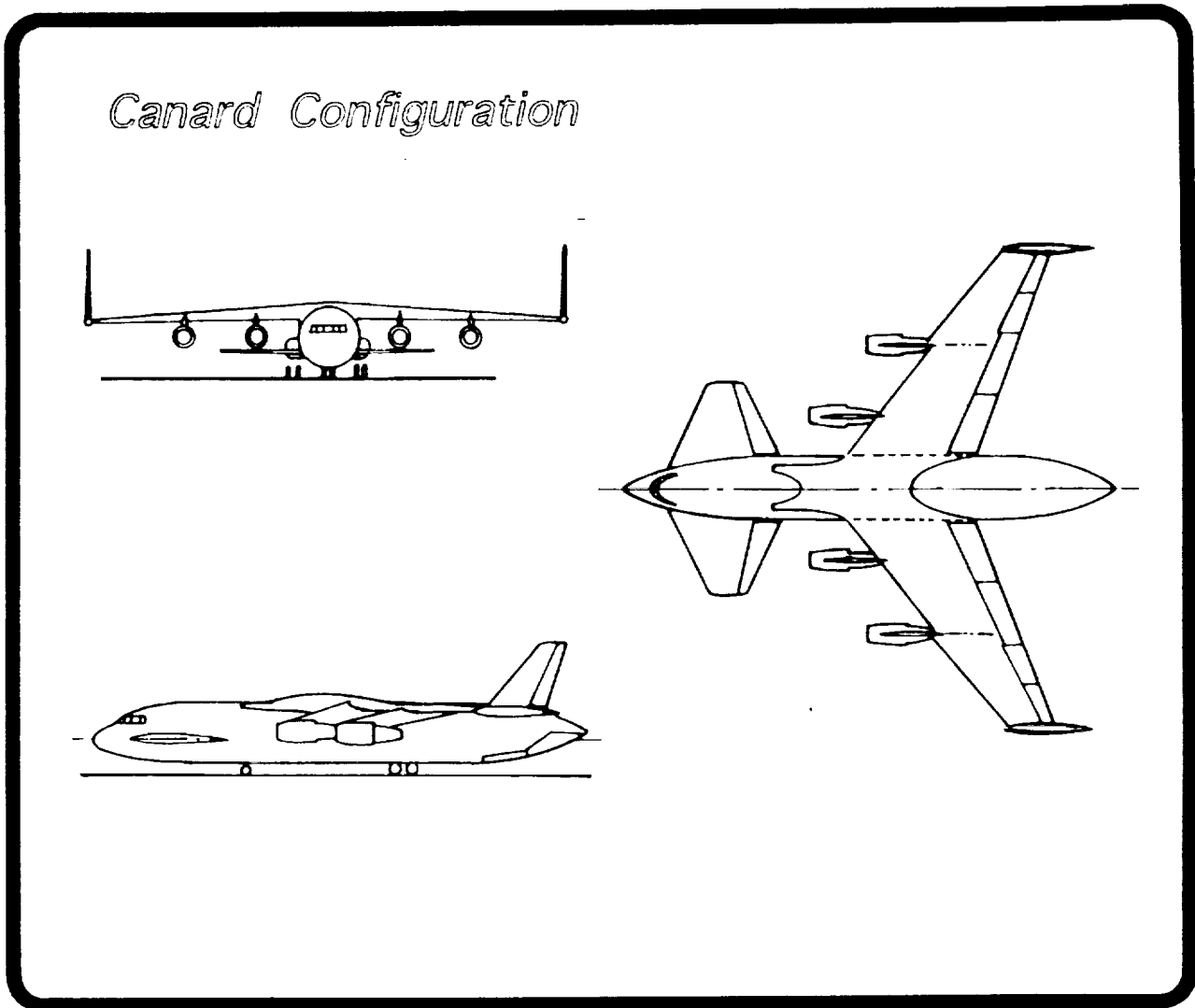

Figure II-3

#### 4. Two Wing

The two wing design split the necessary wing area 40/60 between the forward and aft wings respectively. This resulted in a much smaller wing span (approximately 250 ft) and utilized a higher aspect ratio. The higher aspect ratio resulted in higher induced drag. Initial calculations also showed it to have a CDo higher than the conventional design, Figure II-4.

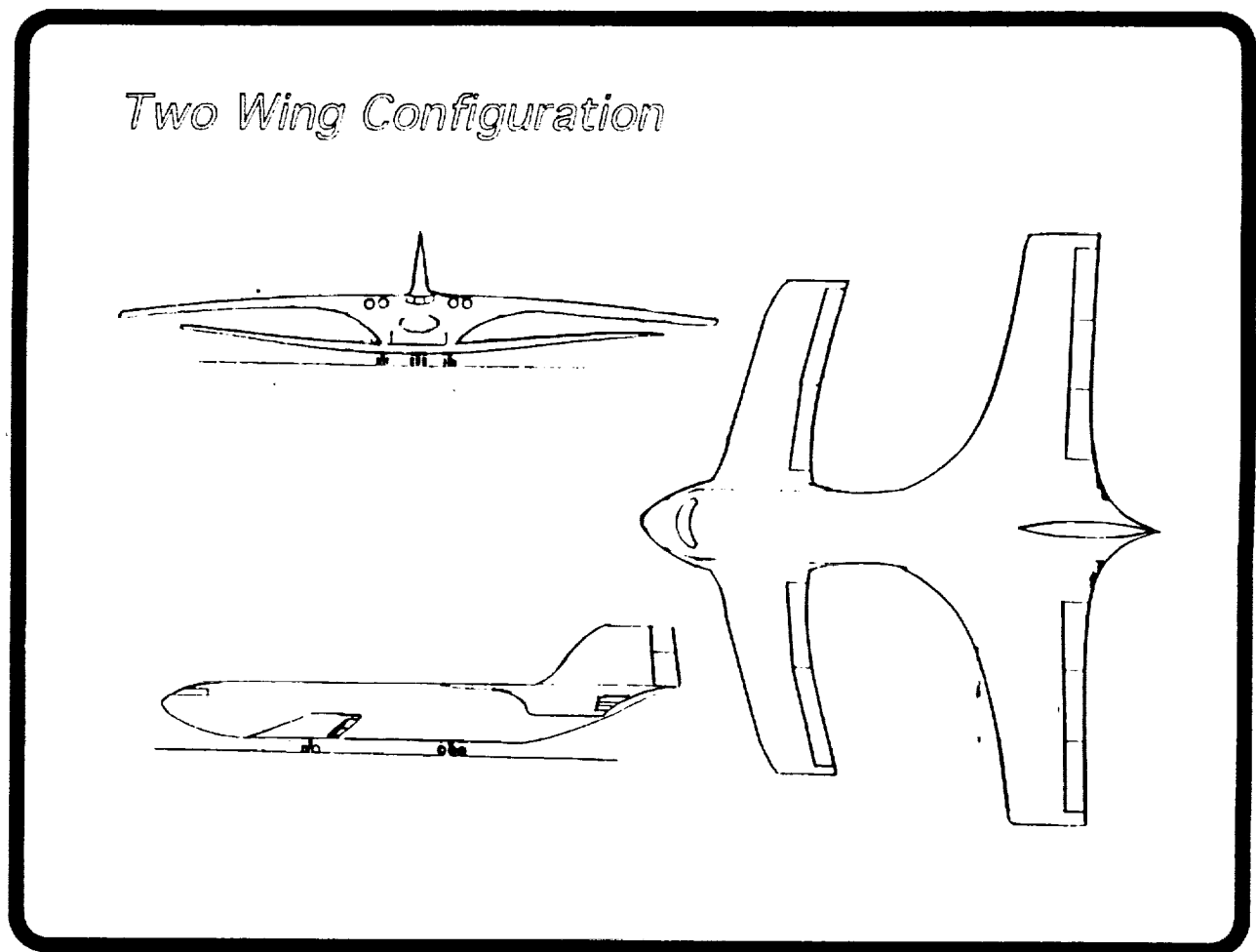

Figure II-4

## 5. Three Wing

This design used three high aspect ratio wings ( $AR=10$ ) to evenly split the required wing area. This design resulted in a wing span slightly greater than the two wing configuration (approximately 300 ft) but did not have the high induced drag problem of the two wing design. Structural integrity of the forward two wings was enhanced by sweeping the middle wing forward to join with the forward wing. This design showed promise though its initial CDo calculation was a little higher than the conventional design. A major drawback with this design was modeling and calculating the aerodynamic interference between the aircraft's wings, Figure II-5.

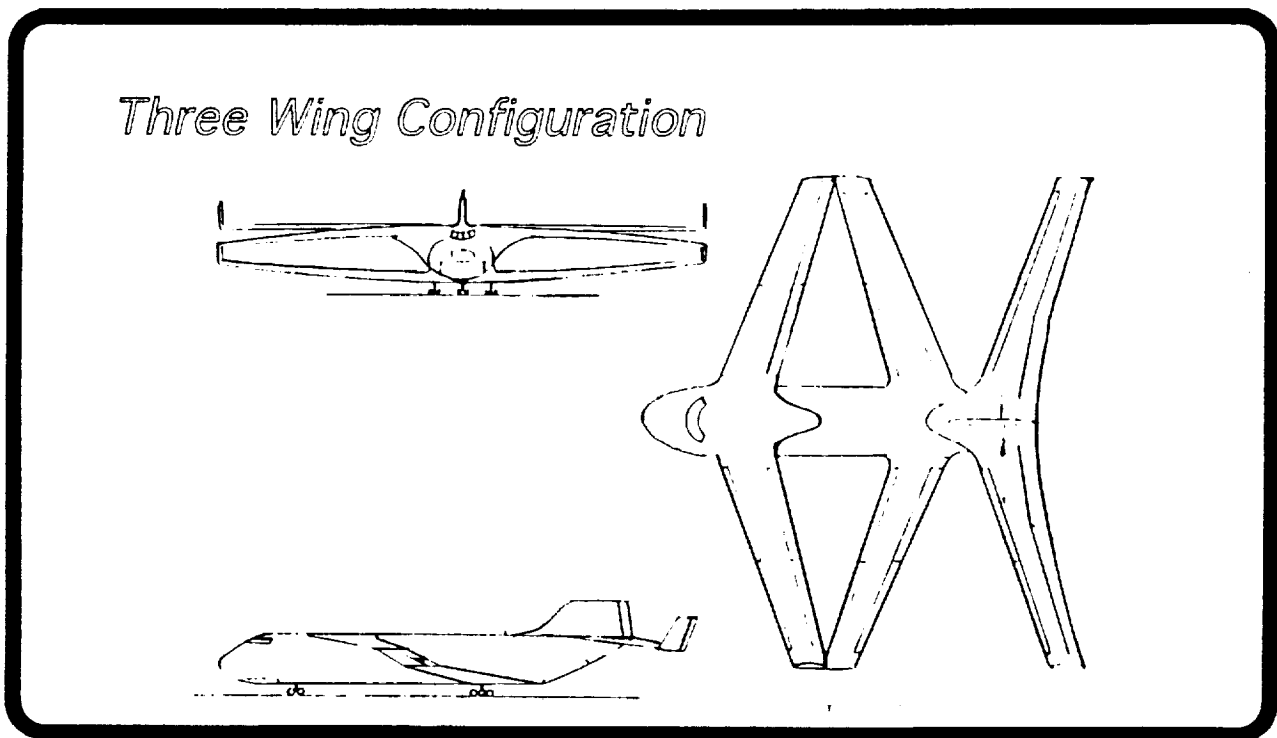

Figure II-5

## C. DUMBO CONFIGURATION

### 1. Final Design Configuration

The configuration decided on for Dumbo was actually a hybrid of some of the designs considered (Figure II-6). The required wing area was divided between the main wing and a large canard/wing, 80/20, respectively. This design gave the higher CI advantages of having a canard. With the canard and an aspect ratio of 10, the main wing span was reduced to 478 ft. CDo was only slightly higher than the conventional design and initial weight calculations showed it comparable to the conventional design. After examining taper ratios, sweep angles, and wing thickness, a supercritical 14% thick airfoil, swept 17 degrees with a 0.41 taper ratio was chosen for both the main wing and canard wing.

### 2. Fuselage

The fuselage design was primarily driven by the cargo area and delivery requirements. The need to carry M-1A Main Battle Tanks drove the floor strength requirements as each tank produces a loading of more than a ton per square foot where the tracks rest. The need to carry AH-1G Cobra helicopters dictated a minimum cargo area height of 14 ft. Using a cargo floor 33 ft. wide allowed for four standard sized cargo lanes, or two M-1A tanks to be placed side by side. This width also allowed for oversized items.

A second deck was placed above the main cargo deck, capable of carrying 250 combat troops and cargo. It could also be configured to carry cargo only. The forward portion of the upper deck consists of the flight deck and crew compartment. Air drop requirements are met using a rear fuselage ramp opening. To meet the one hour on load and off load specification, an opening with ramp at the front of the aircraft was desired.

# Dumbo

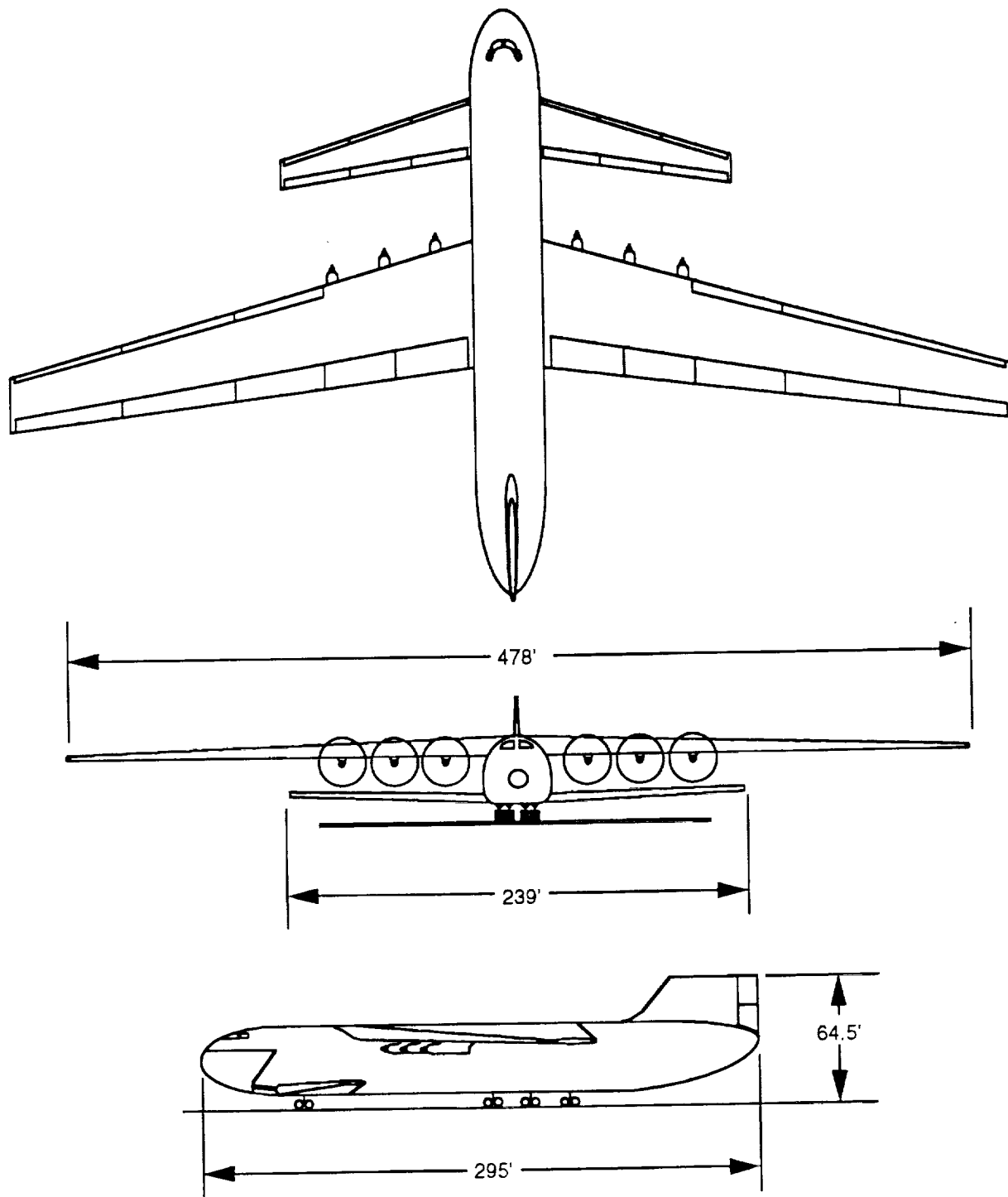

Figure II-6

Several configurations for the front loading scheme were analyzed (Figure II-7), and the raised cab, visor nose was deemed to be the simplest and least expensive, though a fairly significant amount of unusable space will exist in the nose.

### Front Loading Schemes

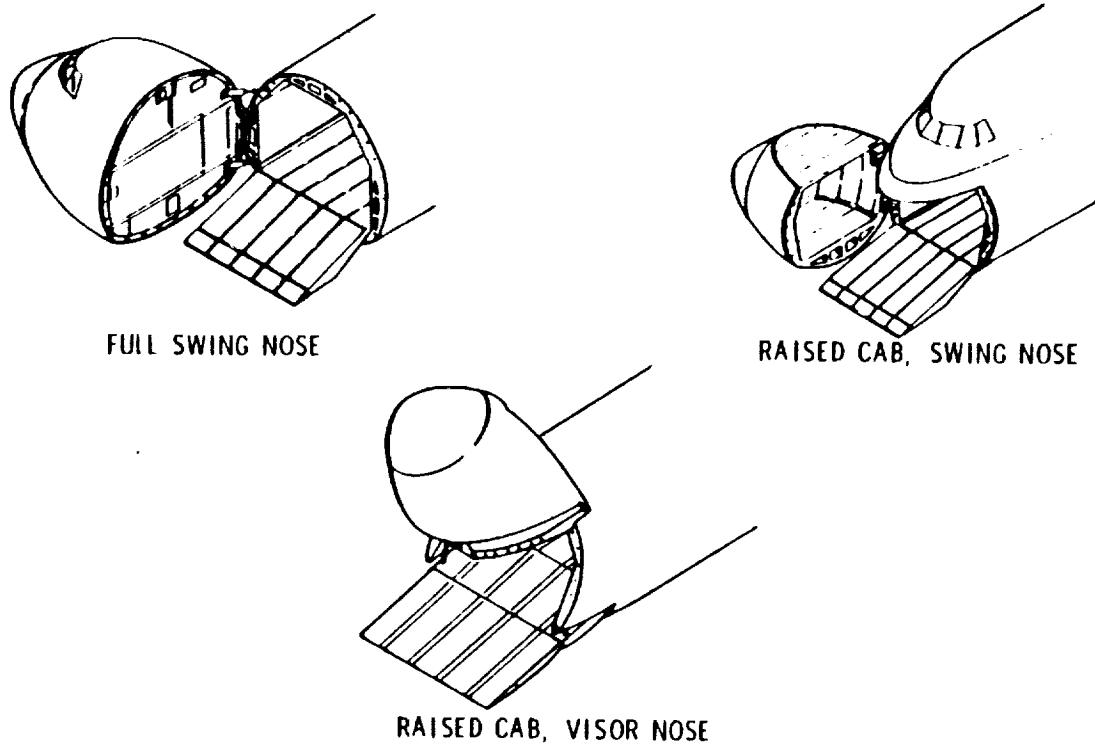

Figure II-7

### 3. Vertical Tail

The vertical tail was initially sized to provide enough directional authority to compensate for the asymmetric thrust of all three engines on one side inoperative in an approach configuration.

#### **4. Engines**

Six unducted, high bypass turbo fans mounted to the underside of the main wing, power the aircraft. Two independent APU's provide air conditioning, electrical and hydraulic power when the main engines are not running; as well as high volume air for the main engines' starters.

#### **5. Landing Gear**

The aircraft rests on six main struts and two nose struts. The main struts have ten tires each and the nose struts eight tires each. All the landing gear retracts forward into enclosed bays, are equipped with brakes, independent steering, and "kneels" approximately five ft.

#### **6. Materials**

The construction of Dumbo will be chiefly composite. All the main structures will be designed to make the most of the state of the art in composite technology. Certain structures, such as the landing gear and hydraulic actuators, will be constructed of more classic materials, including steel and aluminum. Many of the highly localized stress components, such as attachment points and hinge parts will be an optimized combination of metals and composites.

#### **7. Cockpit**

The flight crew of the Dumbo consists of a pilot, copilot, flight engineer, navigator and two load masters. Since dumbo is designed to operate over great distances requiring long flights, accommodations for an entire second crew is provided on board. The flight deck has pilot, copilot, flight engineer and navigator positions. Excellent visibility will be afforded through large wind screens incorporating HUDS. The pilot and copilot have fully redundant controls and displays. Displays consist of CRT's with operator selectable

instruments/displays. Navigational information from an inertial platform, directional and rate gyros, GPS receiver, TACAN, VOR, and ILS receivers, all feed into the main navigation computer. The navigation computer is capable of navigating, point to point anywhere in the world, in all three dimensions. When coupled with the flight control computers, the navigation computer can fly the aircraft from takeoff to landing, choosing the best altitude based on wind and total aircraft weight.

Pilot control inputs are received by Dumbo's two independent flight control computers which agree how best to configure Dumbo's flight controls to provide the aircraft movement input by the pilot. The flight control computers receive position and motion feedback directly from the navigation sub-systems and provides feedback to the pilot's control yoke and rudder pedals. The flight control computers also provide steering inputs to each of the aircraft's landing gear struts. Control signals travel along two physically separated fiber optic data cables to its respective actuator. In the event of any actuator failures, the flight control computer will be capable of compensating with the remaining controls in a manner as transparently as possible to the pilot.

The flight control computer will have similar capabilities with respect to engine power settings when given throttle control; that is, the ability to compensate for the loss of power from one or more engines in a manner as transparent to the pilot as possible.

#### **D. WEIGHT**

The component weights were estimated using statistical techniques from Reference (21). Composites were utilized where ever possible. The empty weight (no crew, fuel or payload) was 1.5 million pounds with a center of

gravity (CG) of 134.8 ft (datum taken from five feet forward of the nose). The maximum gross weight of the aircraft was four million pounds with a CG of 145.7 ft. Dumbo carries 1.7 million pounds of fuel (JP-4) and could be expanded if necessary for larger range. Table II-1 lists the weight and location break down for the takeoff configuration. Figures II-8 and 9 show various CG travel with configuration change and rough CG limits versus aircraft weight.

The allowable CG travel was calculated at takeoff and zero fuel weight conditions. The limits were based on maximum expected values of canard and wing lift capabilities. At takeoff the CG travel limits are 141-157 feet aft of datum, and at the empty weight the CG travel is 110-165 feet aft of datum. As can be seen in Figure II-9, the CG will always be within limits. The largest shift of CG occurs as the 60,000 lb drop is completed and this is also well within limits. The limits were calculated without the use of an automatic fuel transfer system that will continually adjust fuel loading to keep CG travel to a minimum.

Weights, CG, Mom of Inertia, (various config)											
GROUP	MOM ARM REFERENCED FROM "5" FEET IN FRONT OF THE NOSE.										
AIRFRAME	X Arm										
WING (OUT)	177446.7	182	APU	1500		100					
WING (M)	364893	165									
CANARD	243120	72	MISC.								
FUSELAGE	301160	155	TROOP FURNISHINGS	664		155					
NOSE	33645	30	BUNKS	149		50					
TAIL	27645	270	SEATS	732		40					
VERT TAIL	8149	270	FLT DECK SEATS	385		30					
			TROOP SEATS	2234		145					
			LAVATORY	1276		125					
FUEL			BAG AREA	700		70					
WING (JP 4)	1541370	162	Total Weight (lbs)	4000005							
CANARD (JP 4)	158630	77	XCG FROM "5" FEET FORWARD OF NOSE								
BLADDER (C)	3053.9	77									
BLADDER (M)	26620	162	145.7094								
PUMPS AND DRAIN(C)	30	77									
PUMPS AND DRAIN(M)	262.15	165									
CELL BACKING(C)	864	77									
CELL BACKING (M)	6669.9	165									
TRANSFER PUMPS(C)	101	77									
TRANSFER PUMPS (M)	886	165									
			lxx=	5.85E+08	slugs/ft^2						
			lyy=	2.29E+08	slugs/ft^2						
			lzz=	6.2E+08	slugs/ft^2						
			lxy=	0	slugs/ft^2						
			lxz=	26082185	slugs/ft^2						
			lzy=	0	slugs/ft^2						
FWD ENG	22621	139									
MID ENGINES	22621	140									
AFT ENGINES	22621	150									
PROPS FWD	9306.1	123									
PROPS MID	9306.1	130									
PROPS AFT	9306.1	140									
HYD'S											
LANDING GEAR (NOSE)	6743.4	65									
LANDING GEAR (MAIN)	60690.6	160									
HYD SYSTEM	76514	117									
UTILITIES											
FLT INST	438	20									
ENG INST	176	20									
AIR COND	48722	115									
OXY SYSTEM	308.7	20									
PAYLOAD	800000	135									
ELECT SYSTEM	7000	100									
MISC INST	1445	20									

Table II-1

Aircraft CG Travel vs Fuel Burn and Payload Change					
Config #	Wing Fuel(% tot)	Canard Fuel(% tot)	Payload (lbs)	Weight Total	CG Loc.
1	100	100	800000	4000000	145.6
ZFW	0	0	0	1500000	134.8
3	75	75	800000	3575000	144.71
4	50	50	800000	3150000	143.45
5	25	25	800000	2725000	141.8
6	12.5	12.5	800000	2512500	140.76
7	0.12	0	800000	2301849.64	141.7713
8	100	0	0	3041370	141.9
9	50	50	0	2350000	142.68
10	25	50	0	1964657.5	139
11	25	25	0	1925000	140.252
12	12.5	12.5	0	1712500	138.59
13	100	100	60000	3260000	150.08
14	100	100	0	3200000	145.97
15	50	50	60000	2410000	148.38
16	50	50	0	2350000	142.68
LEG 2 17	43	43	120000	2351000	145.61
18	10	10	120000	1790000	142.03

Figure II-8

Acceptable C.G. Envelope

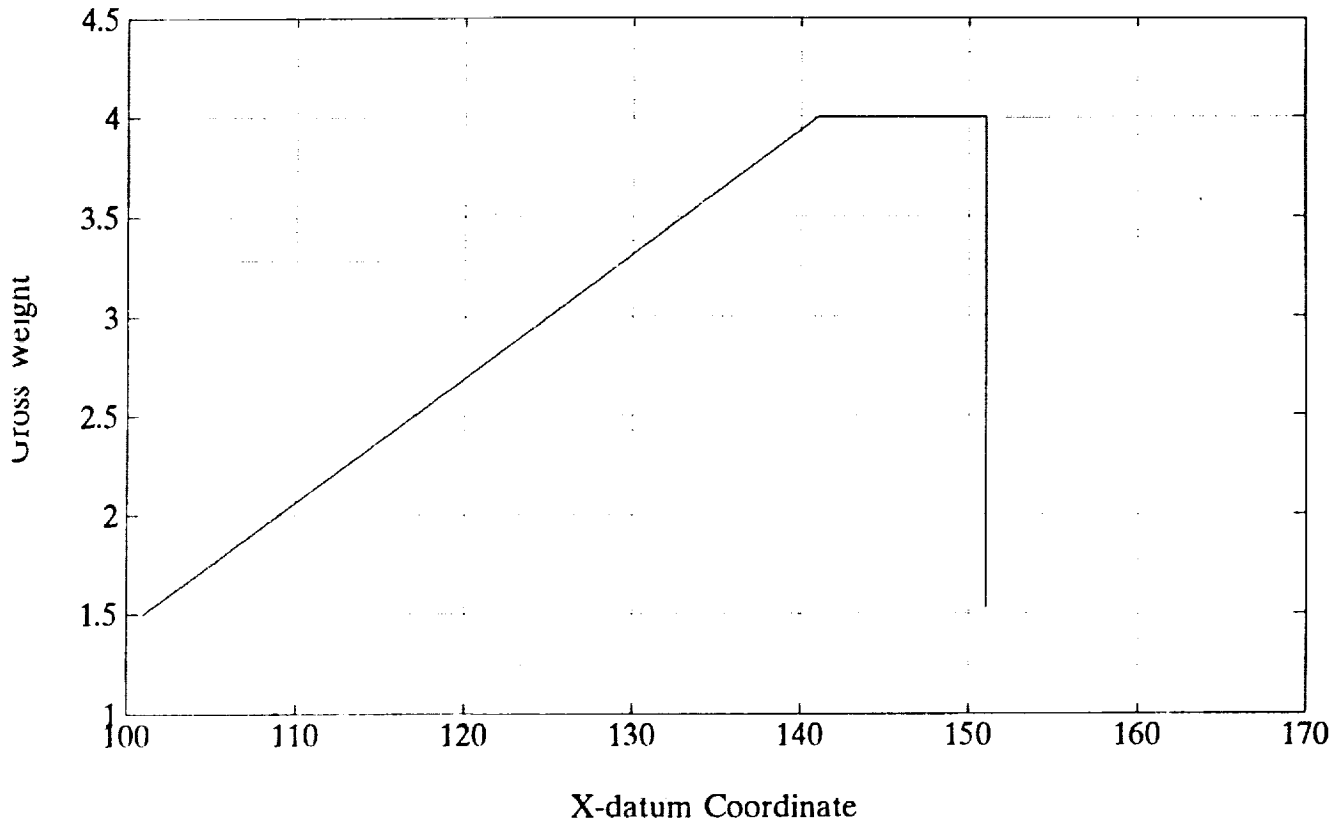

Figure II-9

### **III. AERODYNAMICS**

#### **A. DESIGN GOALS**

The primary goal was to design the most cost-effective long range transport, capable of carrying a sufficient payload to meet transport and deployment requirements in the 21st century.

#### **B. DESIGN RESULTS**

##### **1. Wing Shape Selection**

Given the target cruise Mach of .77 and the high L/D required, it was clear that a wing with a significant wing sweep and a high aspect ratio would be necessary. Too much sweep however would result in dramatic weight increase. The decision was made to use only a moderate wing sweep and to eliminate any drag divergence problems encountered with a supercritical airfoil. The high aspect ratio was also of some concern from a weight standpoint, but keeping K low and the resulting lift curve slope high was of more importance. Based on preliminary weight calculations, Table III-1, an L/D of approximately 21 was found to be necessary if the aircraft was going to be capable of flying the mission profile over the specified range and payload, Reference (21). To achieve an L/D of 21, an aspect ratio of 10 was required Reference (21). This aspect ratio, and initial take-off weight estimate (4,000,000 pounds vice 3,636,000 derived in Table III-1 was used to initially provide conservative numbers that could later be refined.) A wing leading edge sweep of 17 degrees resulted in a critical Mach number above the design point.

PRELIMINARY TAKEOFF WEIGHT CALCULATIONS

		WTO=	3696000	
START=	0.995			
TAXI=	0.995			
T/O=	0.995	VARIABLES		
CLIMB=	0.98			
		L_D=	21	
		V =	460	
		CJ=	0.37	
		RA=	5850	
CRUISE=	0.799260525			
DESCENT=	0.995			
LAND/TAXI=	0.992			NOTE
MFFA=	0.761585093			FUEL FRACTION
WT1=	881181.4972			WT JUST PRIOR
WT2=	201181.4972			WT AFTER OFF
TAXI2=	0.995			
TAXI2(CORR)=	0.998858456			WT CORRECTED
T/O2=	0.995			PAYLOAD OFF
CLIMB2=	0.98			
CRUISE2=	0.799260525			
DESCENT2=	0.995			
LAND/TAXI2=	0.992			
		WT EMPTY CALCULATIONS		
MFF=	0.585186985	WF=	1533148.905	
		WOE(TENT)=	1362851.095	
		WE(TENT)=	1357255.095	
WTO=	3696000	WE=	1357293.283	

Table III-1

## 2. Airfoil Selection

As with most transonic aircraft, the Dumbo will operate in a flight regime where proper airfoil selection is critical to performance. An airfoil was needed that would, 1) be thick enough to save weight and store the required fuel, 2) limit the large wing sweep usually associated with transonic aircraft, thereby saving weight, and 3) possess a high  $C_{L_{max}}$ . Based on the above requirements, it was clear that a supercritical airfoil was necessary. The NASA SC(2)-0714 airfoil was chosen for the aircraft. The airfoil is shown in Figure III-1. The supercritical airfoil will allow less wing sweep (due to a higher divergent Mach number) and a thicker wing, both of which result in a savings in weight. This means less fuel required and lower operating costs. Wing thickness was selected based on the volume of fuel required to perform the 12,000 nautical mile mission and the decision to utilize a supercritical airfoil.

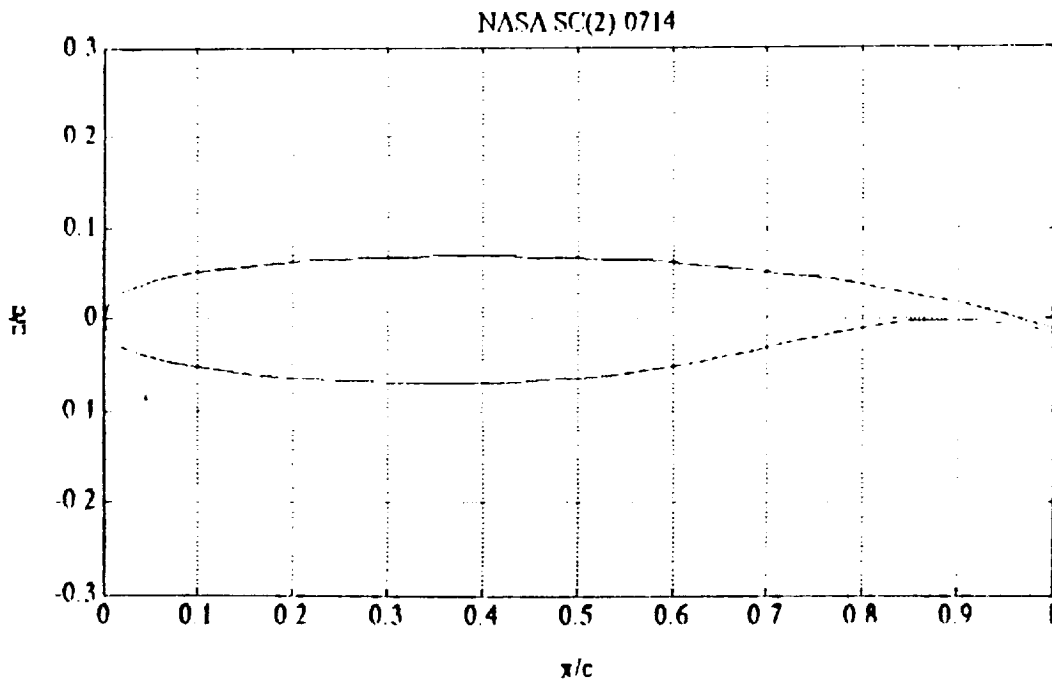

Figure III-1

### **3. Lift Curve Slope**

Analysis of the Dumbo lift curve slope was performed in accordance with the procedures outlined in References (18) and (21). The lift curve slope improved with increasing Mach number due to compressibility effects. The Dumbo aircraft had lift curve slopes of 5.04/rad at Mach = 0.20, 5.51/rad at Mach = 0.50 and 6.57/rad at Mach = 0.75.

### **4. High Lift Devices**

In order to make takeoff and landing speeds slow enough to operate with current runway lengths, a  $C_l$  max of at least 3.0 was required. In order to achieve this  $C_l$  max, leading/trailing edge flaps were required in combination with a super critical airfoil. Preliminary estimations show that trailing edge devices increase the maximum lift coefficient by 0.71 and leading edge devices increase the maximum lift coefficient by 0.32. It should be noted that although this preliminary design includes leading edge flaps, further investigation into the feasibility of slats is recommended. Figure III-2 shows the lift-curve slope including high lift devices.

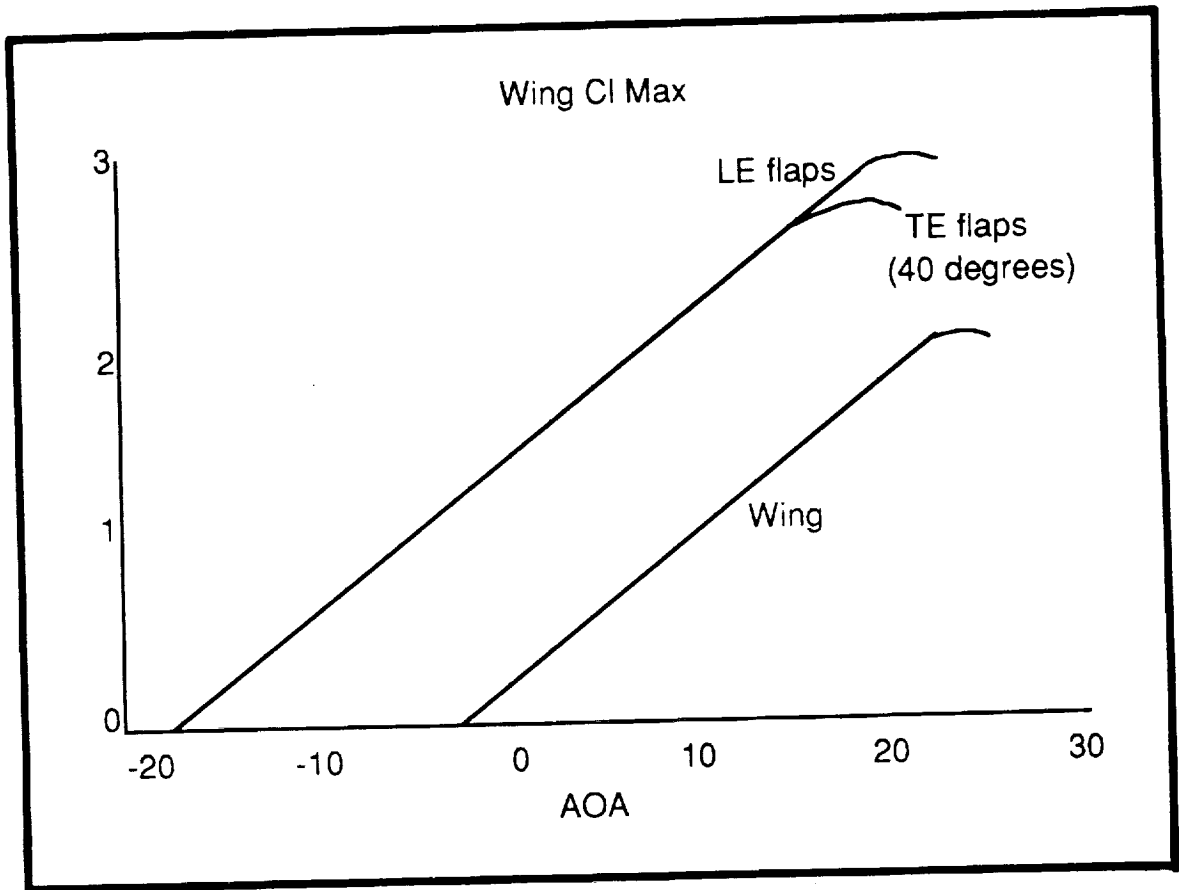

Figure III-2

## 5. CDo Calculation

CDo was calculated as given in Table III-2 at cruise altitude and Mach. The methodology was from Reference(18). The calculated CDo of 0.011, is reasonable (but perhaps a little low) and should remain constant over the intended subsonic flight regime.

CD<sub>0</sub> Calculation

CD <sub>0</sub> CALCULATIONS FOR CANARD CONFIGURATION			
COEFFICIENTS			
TC=	0.14	THICKNESS RATIO	
CT=	28	TIP CHORD	
CR=	68	ROOT CHORD	
CRT=	34	ROOT CHORD (CANARD)	
CTT=	14	TIP CHORD (CANARD)	
CRV=	100	ROOT CHORD (VERT TAIL)	
CTV=	50	TIP CHORD (VERT TAIL)	
Lb=	320	BODY LENGTH	
D=	37	BODY DIAMETER	
Db=	0	BASE DIAMETER	
V=	766	FREESTREAM VELOCITY (FT/SEC)	
mew=	0.0003488	FREESTREAM $\mu$	
SWSB=	19.8	SW/SB (FROM DATCOM)	
SW=	17	LEADING EDGE SWEEP	
SWT=	17	CANARD SWEEP	
SWV=	45	VERTICAL TAIL ANGLE	
B=	515	SPAN (WING)	
BT=	276	SPAN (CANARD)	
HT=	50	HEIGHT OF VERT TAIL	
CD <sub>0</sub> W=	0.0055273	WING CD <sub>0</sub>	
CD <sub>0</sub> B=	0.00154277	CD <sub>0</sub> BODY	
CD <sub>0</sub> HT=	0.00326838	CD <sub>0</sub> HORIZONTAL TAIL	
CD <sub>0</sub> VT=	0.0007907	CD <sub>0</sub> VERTICAL TAIL	
CD <sub>0</sub> =	0.01112915	CD <sub>0</sub> TOTAL AIRCRAFT	
CD <sub>0</sub> CALCULATION FOR FWD PANEL (WING)			
lam=	0.41176471	LAMDA (CT/CR)	
MAC=	50.7777778	MEAN AERODYNAMIC CHORD	
REc=	111513124	RE USING MAC	
CF=	0.00209619	SKIN FRICTION COEFFICIENT USING RE	
		CD <sub>0</sub> W=	0.0055273

Table III-2

C<sub>Do</sub> Calculation

C <sub>Do</sub> CALCULATION FOR ISOLATED BODY			
RE <sub>b</sub> =	702752294	RE USING BODY LENGTH	
CF <sub>b</sub> =	0.00164173	SKIN FRICTION COEFFICIENT USING RE	
l <sub>bd</sub> =	8.64864865	FINENESS RATION (L <sub>b</sub> /D)	
C <sub>Do</sub> F=	0.03547063	C <sub>Do</sub> FRICTION-BODY	
C <sub>Do</sub> bp=	0	C <sub>Do</sub> BASE PRESSURE-BODY	
C <sub>Do</sub> BF=	0.03547063	BODY C <sub>Do</sub> (Based on frontal area)	
SB=	1075.17838	BODY FRONTAL AREA	
SW1=	0.29669722	LEADING EDGE SWEEP IN RADIAN	
CTA=	78.7231866	TIP CHORD PRIME	
CRA=	38.7231866	ROOT CHORD PRIME	
S <sub>lp</sub> =	24720	WING PLANFORM AREA	
		C <sub>Do</sub> B=	0.00154277
C <sub>Do</sub> CALCULATION FOR ISOLATED HORIZONTAL TAIL			
lam <sub>t</sub> =	0.41176471	LAMDA TAIL (CTT/CRT)	
MACT=	25.3888889	MEAN AERODYNAMIC CHORD (TAIL)	
RE <sub>t</sub> =	55756562.2	RE BASED ON RE <sub>t</sub>	
CFT=	0.00231286	COEFFICIENT OF FRICTION (TAIL)	
C <sub>Do</sub> ha=	0.00609861	C <sub>Do</sub> BASED ON S <sub>ap</sub> (TAIL)	
S <sub>ap</sub> h=	13248	HORIZONTAL TAIL PLANFORM AREA	
		C <sub>Do</sub> HT=	0.00326838
C <sub>Do</sub> CALCULATION FOR ISOLATED VERTICAL TAIL			
lam <sub>v</sub> =	0.5	LAMDA VERTICAL TAIL (CTV/CRV)	
MACV=	77.7777778	MEAN AERODYNAMIC CHORD VERT TAIL	
RE <sub>v</sub> =	170807849	RE USING MACV	
CFV=	0.00197669	FRICTION COEFFICIENT USING RE <sub>v</sub>	
C <sub>Do</sub> va=	0.0052122	C <sub>Do</sub> BASED ON S <sub>ap</sub> OF VERTICAL TAIL	
S <sub>ap</sub> v=	3750.05791	VERTICAL TAIL PLANFORM AREA	
		C <sub>Do</sub> VT=	0.0007907
		C <sub>Do</sub> =	0.01112915

Table III-2 (con't)

## 5. Drag Polars

The linearized drag polar for the Dumbo aircraft in the clean configuration is shown in Figure III-2. The drag polar uses the assumed Oswald efficiency factor of 0.8 and a  $C_{D0}$  of 0.013. The chart was used to predict drag values at various phases of flight. This aided in the determination of propulsion requirements. Also included is the linearized drag polar for the Dumbo aircraft in the landing configuration, Figure III-3.

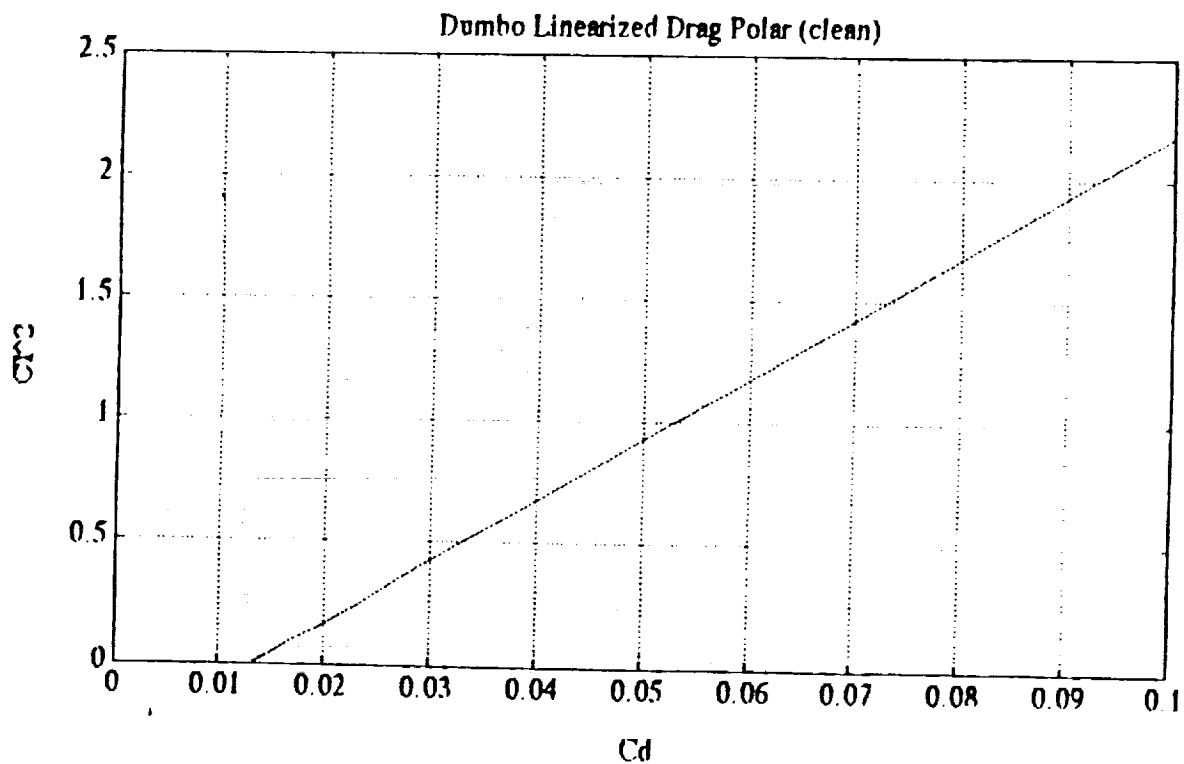

Figure III-2

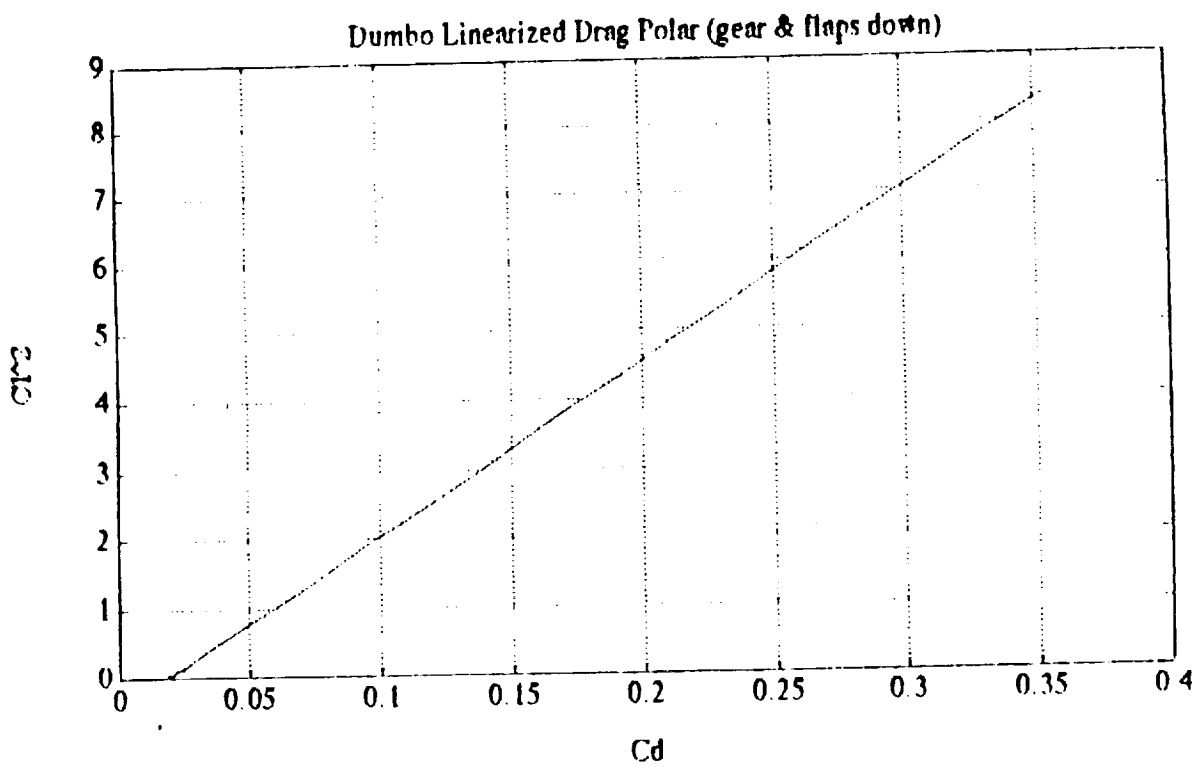

Figure III-3

## IV. PROPULSION

### A. INTRODUCTION

The performance of any aircraft is determined by the capabilities of the engine selected for incorporation into the airframe. Therefore it is vital that the power plant selected for the Dumbo global transport be capable of operation throughout the flight envelope required by the mission specifications.

Power plant selection for the Dumbo was performed in three steps. First the flight regime of the aircraft was determined via the request for proposal (RFP) and the overall design objectives for the aircraft. Second, suitable power plant options were investigated in order to determine which types of engines would meet the design goals. Last, the design of the power plant including prop-fan sizing and core gas turbine design were accomplished in accordance with References (22) and (28).

#### 1. Flight Requirements

The flight regime of the Dumbo transport as stated in the RFP were to fly 6500 nm with full payload at a cruise Mach number of 0.77, land and return with a 15% full load with out refueling as its primary mission. The secondary mission is to fly 8000 to 12000 nm at 75% full payload, land and return empty with out refueling. The constraint analysis determined that the takeoff thrust to weight ratio was 0.22 with an estimated take off gross weight of 4,000,000 lbs, resulting in a take off thrust requirement of 880,000 lbf. In order to keep aircraft weight down, the structural loading to a minimum and keep the thrust per engine to a realistic value for the target date, the decision was to limit the aircraft to 6 engines. Therefore each engine would be required to produce

146,700 lbf of thrust at take-off. This coupled with the RFP requirement for long range dictates that the power plant would require a high thrust output with a low cruise specific fuel consumption (sfc). It was determined that there were no current power plants in existence that met these requirements, therefore a new engine was designed for this aircraft.

The power plant options available were turbo jet, turbo prop, turbo fan and unducted prop-fans. The mission requirements of low SFC and a cruise Mach number of 0.77 eliminated the turbo jet and the turbo prop. Therefore the comparison was limited to turbo fan and unducted prop- fans.

## **2. Power Plant Selection**

Various studies have indicated that there is a large performance advantage at cruise speeds up to Mach 0.8 for advanced high speed prop-fan aircraft as compared to high bi-pass ratio turbo fans. These advantages will result in large block fuel savings, reduced life cycle costs and improved range for both civil and military aircraft Reference (1).

The two power plants compared were a turbo fan with a bi-pass ratio of 20 and an unducted prop-fan(UDF). Figure IV-1 shows the cruise SFC for each at a Mach number of 0.77 and an altitude of 35,000 ft. Clearly the UDF displays a significant fuel savings over the turbo fan. Therefore the UDF power plant was determined to be the best choice to meet the range requirement of the Dumbo global transport.

# SFC vs THRUST (M=.77, ALT 35000)

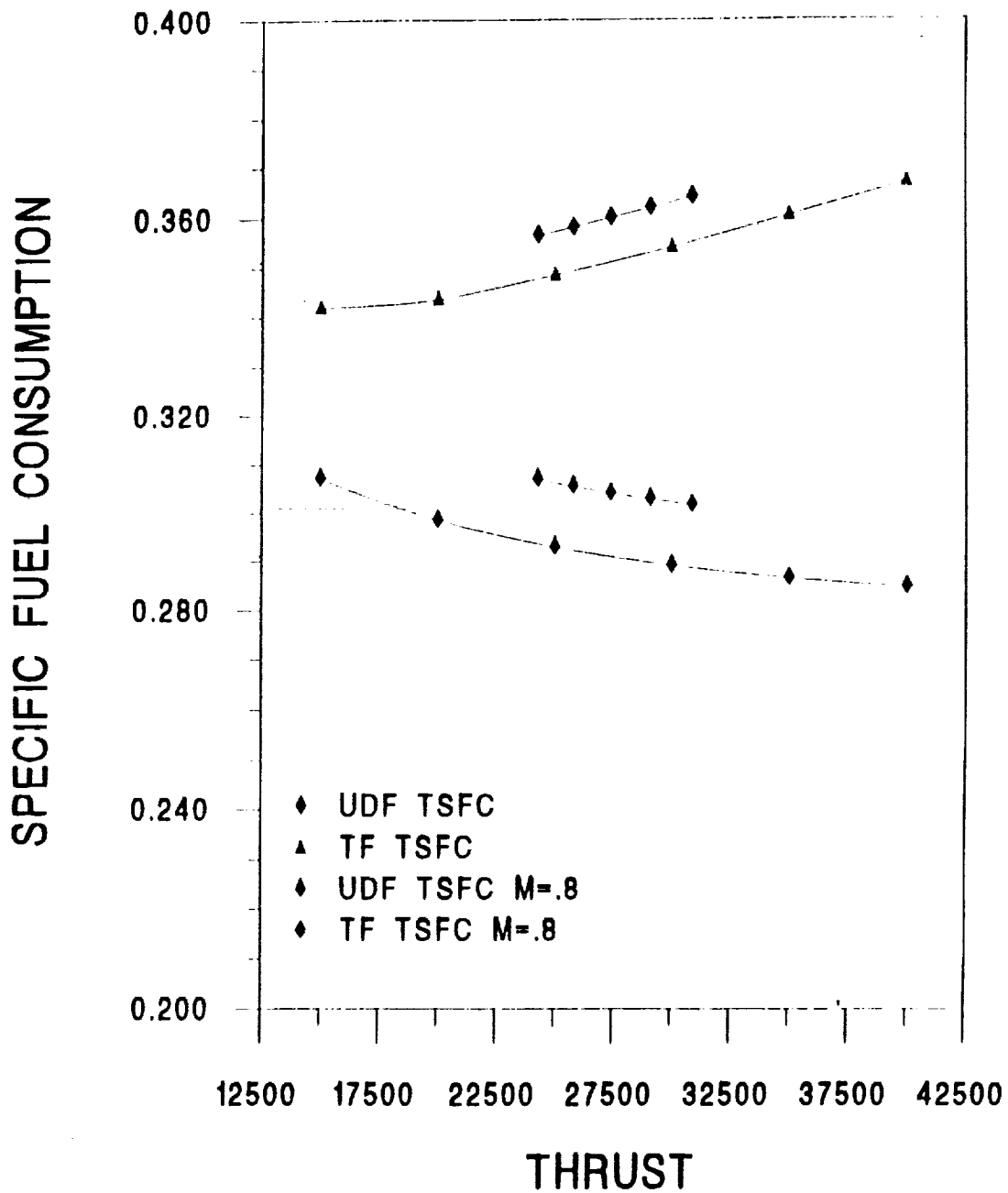

Figure IV-1

### **3. Power Plant Design**

#### **a. Core**

The UDF selected for Dumbo was based on the new General Electric GE-90B1 turbofan engine from Reference (6). The GE-90B1 has a sea level maximum power specific fuel consumption value of 0.278. It is shown that UDF's offer a 15 to 30% reduction in SFC. Because the GE engine is new, a 15% reduction is believed possible. Another 10% reduction in sfc is deemed possible through technology improvements by the year 2015.

Using Mattingly's ONX/OFFX program and a target sfc of 0.213, the UDF was modeled after a turbo prop. The final core engine design has a maximum pressure ratio of 45, an sfc of 0.2099 and a compressor frontal area of 6.7 sqft.

#### **b. Fan**

The next step was the sizing of the prop-fan blades to meet the thrust requirements of Dumbo. The only design data available was supplied by Reference (22) which contains parametric data for a single disc 10 blade prop-fan. Utilizing this data and the thrust requirements an initial size for the fan diameter was computed to be approximately 34.6 ft. which seemed quite excessive. Therefore a counter rotating prop-fan was examined to try to reduce disc diameter.

A counter-rotating prop-fan (CRP) would allow for increased disc loadings and higher propulsive efficiency levels. The CRP efficiency is improved not only by reducing the load on each blade but by eliminating swirl energy losses which is captured by the second disc, Reference (8). There was no

data available on how to size a CRP therefore an assumption was made based on NASA's prop-fan in which a 30% reduction in diameter was achieved by adding a second counter-rotating disc, Reference (8). Therefore the overall diameter of Dumbo's prop-fan was reduced to 24.2 ft. Another benefit to the double 10 bladed configuration is noise reduction. The noise levels are lower than FAR 25 stage 3 restrictions, -1dB for sideline, -5dB for take-off and -4dB for approach, Reference (25).

Figures IV-2 and IV-3 show the relationship of diameter to disc loading for a range of tip speeds for take off and cruise in order to optimize the performance of the prop-fans. At sea level take-off conditions the prop-fan will have a disc loading of approximately  $120 \text{ SHP}/D^2$  and a tip speed of 800 fps. For cruise, a disc loading of  $36 \text{ SHP}/D^2$  and a tip speed of 789fps are optimum. Figure IV-4 shows the expected propulsive efficiency versus disc loading for the Dumbo transport. The thrust output versus Mach number and altitude is shown in Figure IV-5. Figure IV-6 denotes the military thrust sfc as a function of Mach number and altitude. Figure IV-7 shows the over all specifications of the engine selected.

### SEA LEVEL TAKE OFF THRUST C-R DISC SIZING

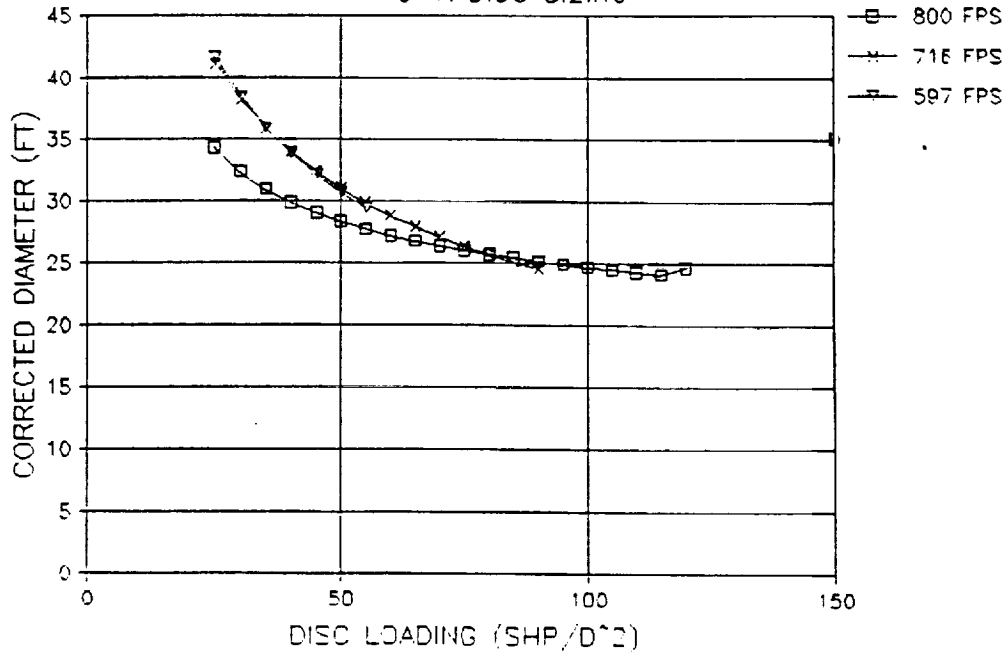

Figure IV-2  
35000 FT CRUISE THRUST  
C-R DISC SIZING

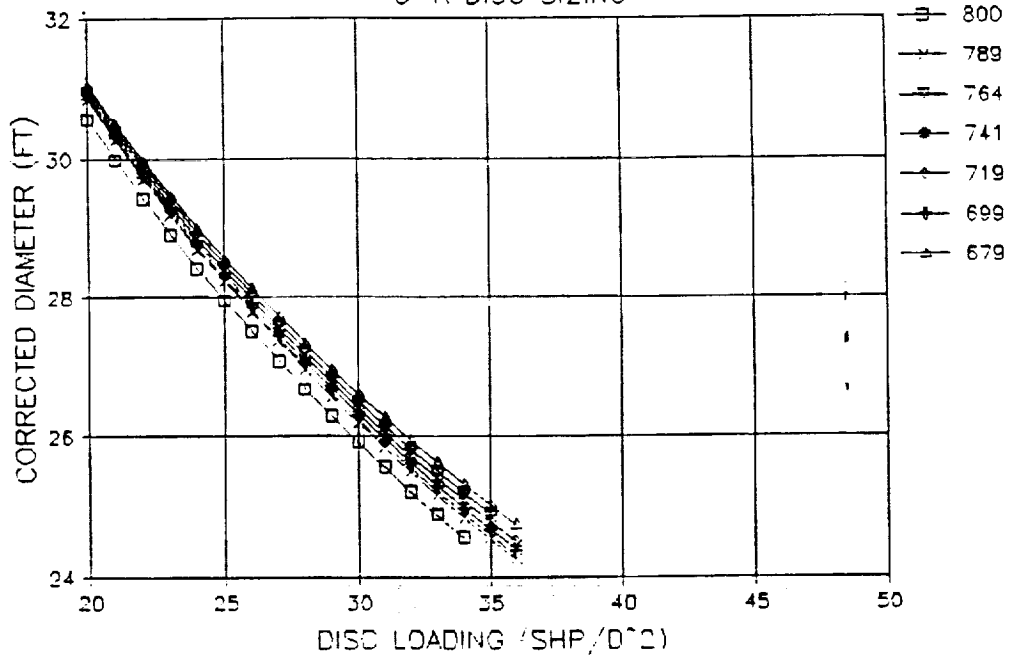

Figure IV-3

# PROPULSIVE EFFICIENCY vs DISC LOADING

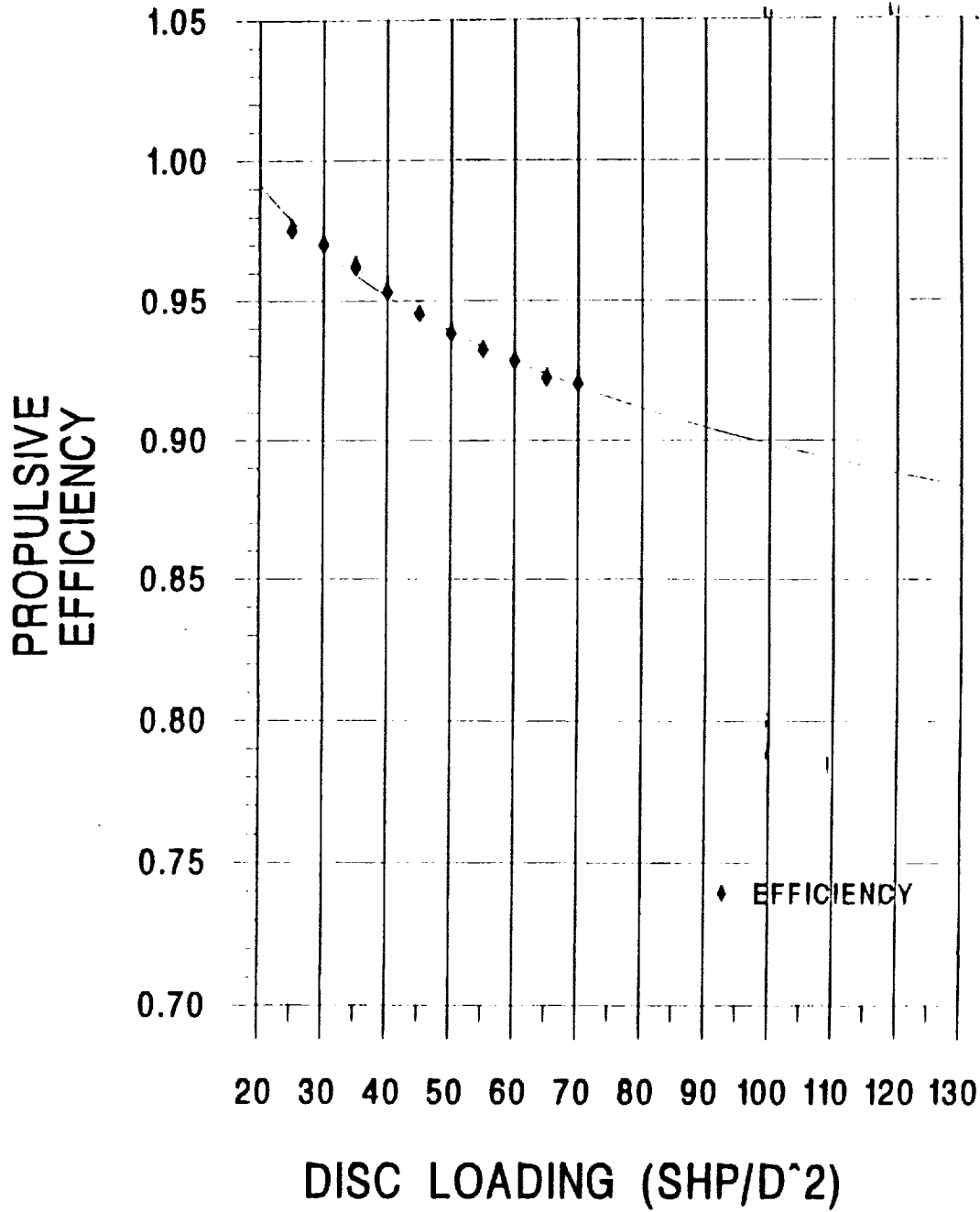

Figure IV-4

# THRUST vs MACH# and ALTITUDE

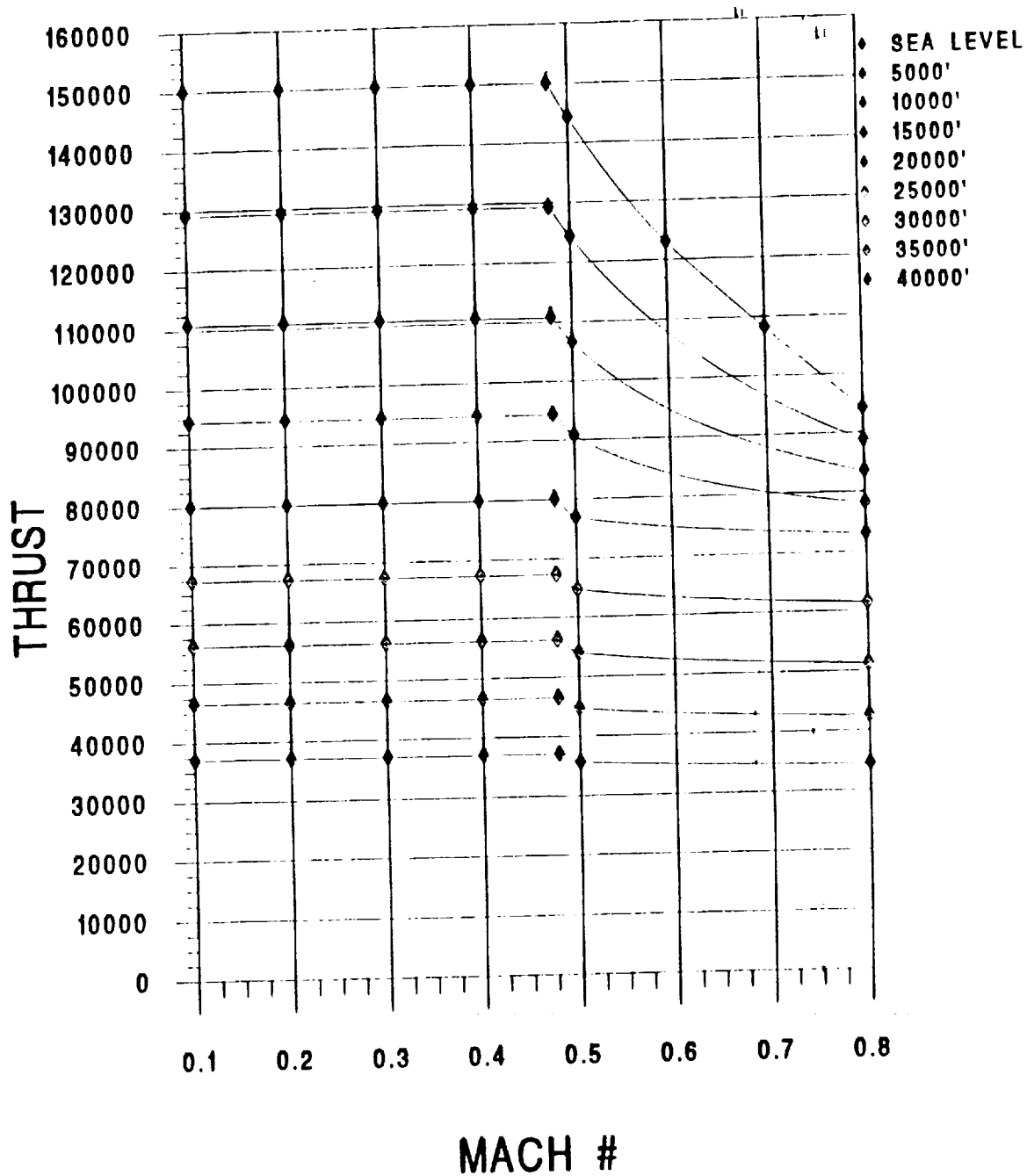

Figure IV-5

# TSFC vs MACH# and ALTITUDE (MILITARY THRUST)

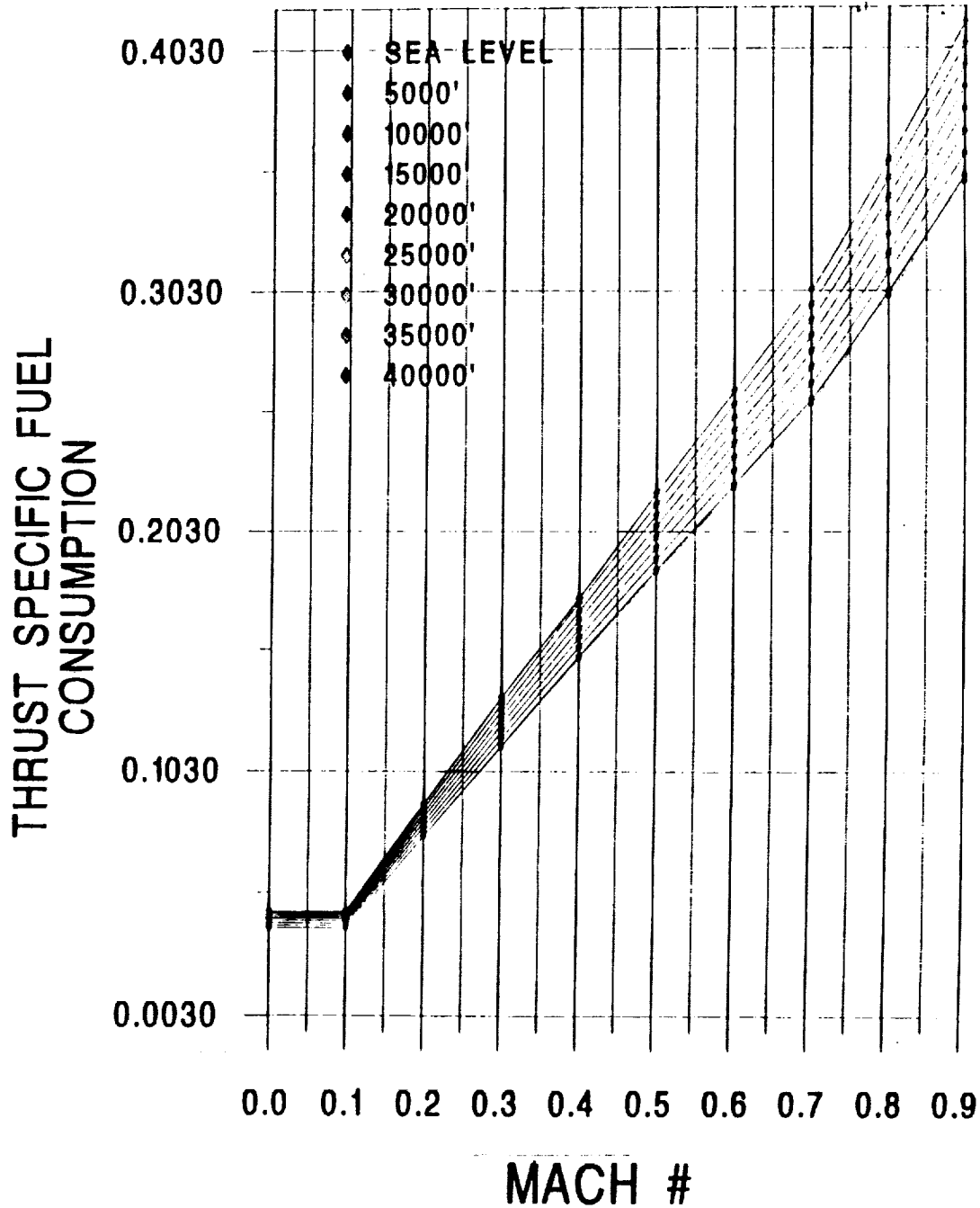

Figure IV-6

SPECIFICATION	DUMBO ENGINE
Weight (lbs)	11300
Thrust (lbs)	150000
Bypass Ratio	40-45
SFC (SL, static)	.2099
Disc Loading (shp/ft <sup>2</sup> )	120
No. of Blades	10 x 10
Nacelle Diameter (ft)	4.5
Fan Diameter (ft)	24

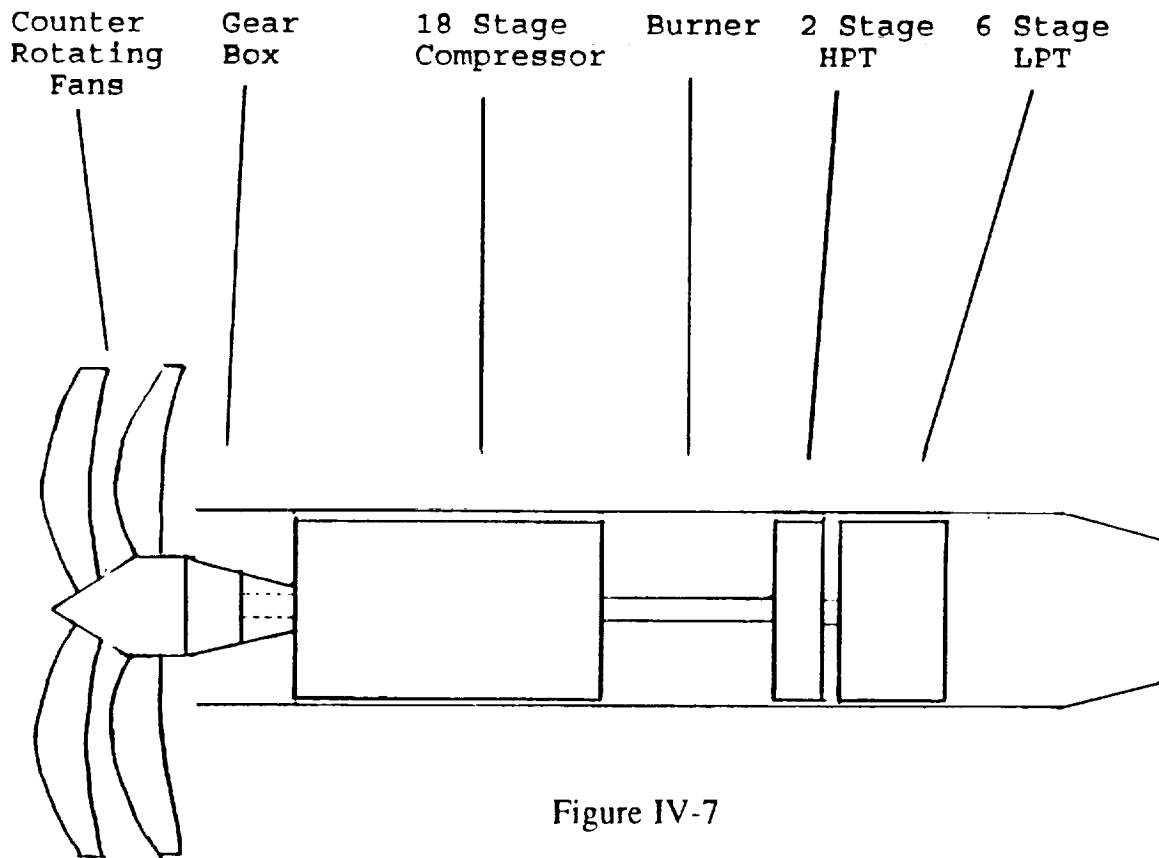

Figure IV-7

## V. STRUCTURAL ANALYSIS

### A. STRUCTURES

#### 1. Design Goals

The structural design loads were delineated by the RFP. The aircraft was to be capable of carrying large payloads while at the same time having a substantial range in order to service bases located throughout the world. Additionally, the aircraft had to be able to withstand a 2.5g loading.

#### 2. Materials

A large portion of the aircraft structure was chosen to be composites, primarily due to composites ability to reduce aircraft weight while maintaining high directional strength. Additional benefits of composites are their substantial fatigue resistance and low susceptibility to corrosion. The higher cost of these advanced materials is balanced by the need for fewer components due to unitized construction.

#### 3. V-N Diagram

The V-N diagram, Figure V-1 for Dumbo at sea level and weighing four million pounds was computed per MIL-A-8861B and RFP requirements. The lift equation was used to construct the left hand boundary of the operations envelope. This equation can be written in the form of load factor (n) as a function of velocity. Velocity to never exceed (Vne) was calculated by multiplying cruise speed by 1.25(0.9 Mach). The point where the limit load meets the maximum lift curve is called the maneuvering speed and is approximately 385 fps, or 227 KEAS. The stall speed line corresponds to an equivalent airspeed of 198 fps (117 KEAS).

Another consideration in developing Dumbo's operating envelope was gust loading. Gust loads were applied at three points on the V-N diagram in accordance with MIL-A-8861. The gust envelope for the aircraft was completely within the operating envelope; therefore the operating envelope became the constraint diagram for structural design.

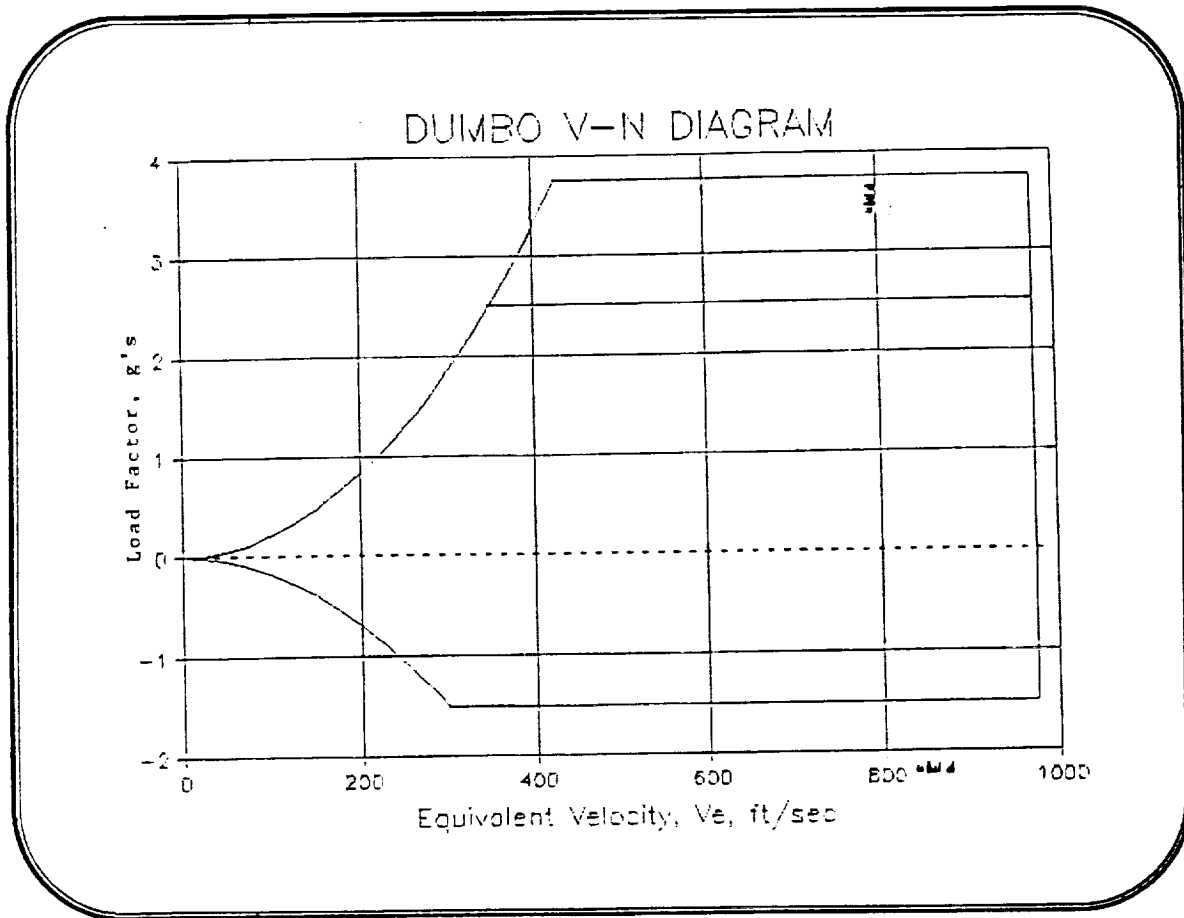

Figure V-1

#### 4. Wing Design

An analysis was conducted of the wing in order to determine the forces and stresses encountered during flight. Three conditions were looked at: 1) at rest on the ground, 2) at cruise Mach and altitude, and 3) at the aircraft's ultimate load (3.75g) while at cornering speed. Obviously the largest loads were encountered at 3.75g and this is what the aircraft's structure was designed to withstand.

First, a simple analysis of the airfoil was conducted. The following charts, Figure V-2 and Figure V-3 show the spanwise lift distribution and the chordwise  $C_p$  profile.

Detailed shear and moment diagrams were constructed for the three conditions discussed earlier. The most critical ones are shown below as Figures V-4 and Figure V-5.

From these charts, the maximum moment is shown to occur at the wing root at a value of approximately  $3.75 \times 10^8$  ft-lbs with a maximum shear value of approximately  $4.3 \times 10^6$  lbs. Also from the information shown, it can be determined how the values decrease toward the wing tip. This information was then used to size the wing spars with a varying cross-sectional area such as the one shown in Figure V-6. This concept resulted in a saving in weight while maintaining sufficient structural integrity.

Pressure Distribution Across Root Chord

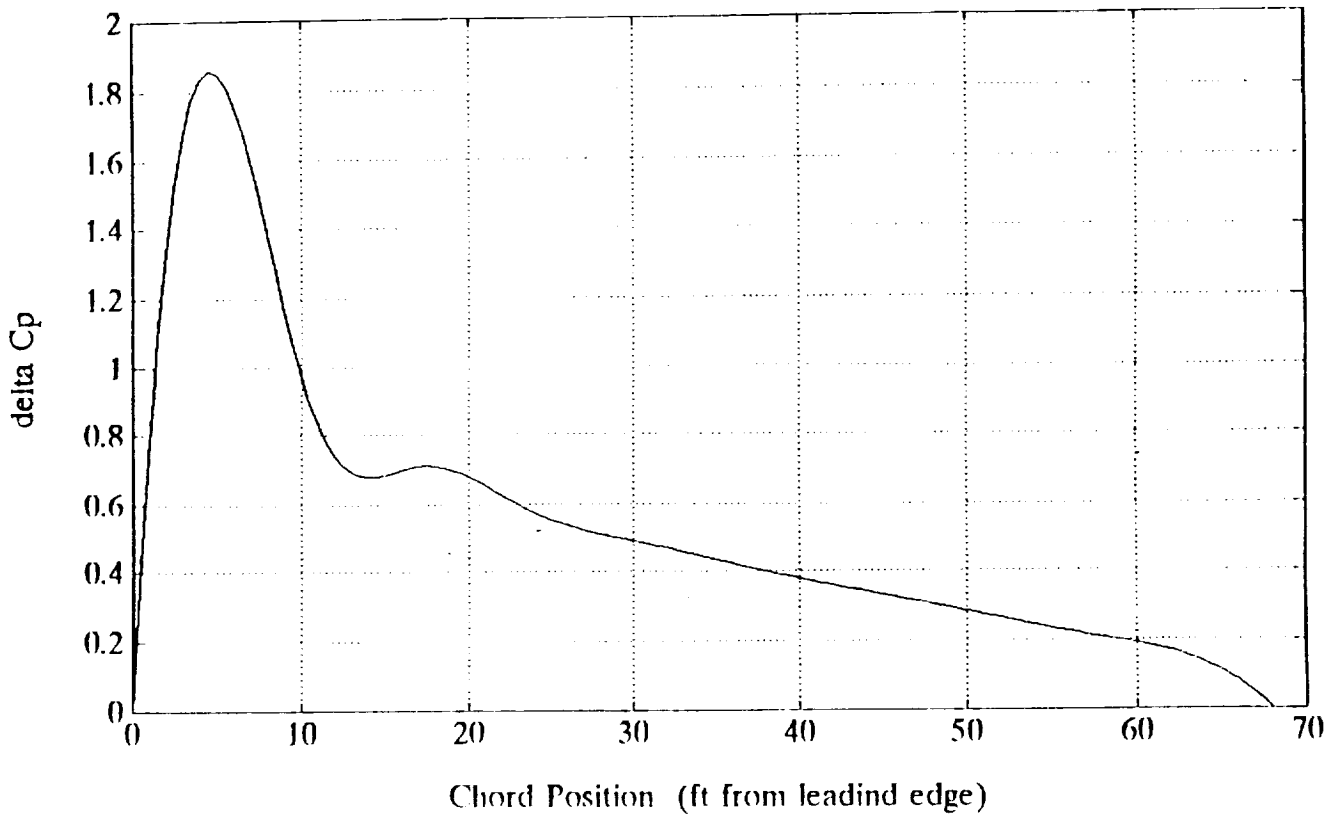

Figure V-2

Lift Distribution Across Wing Span

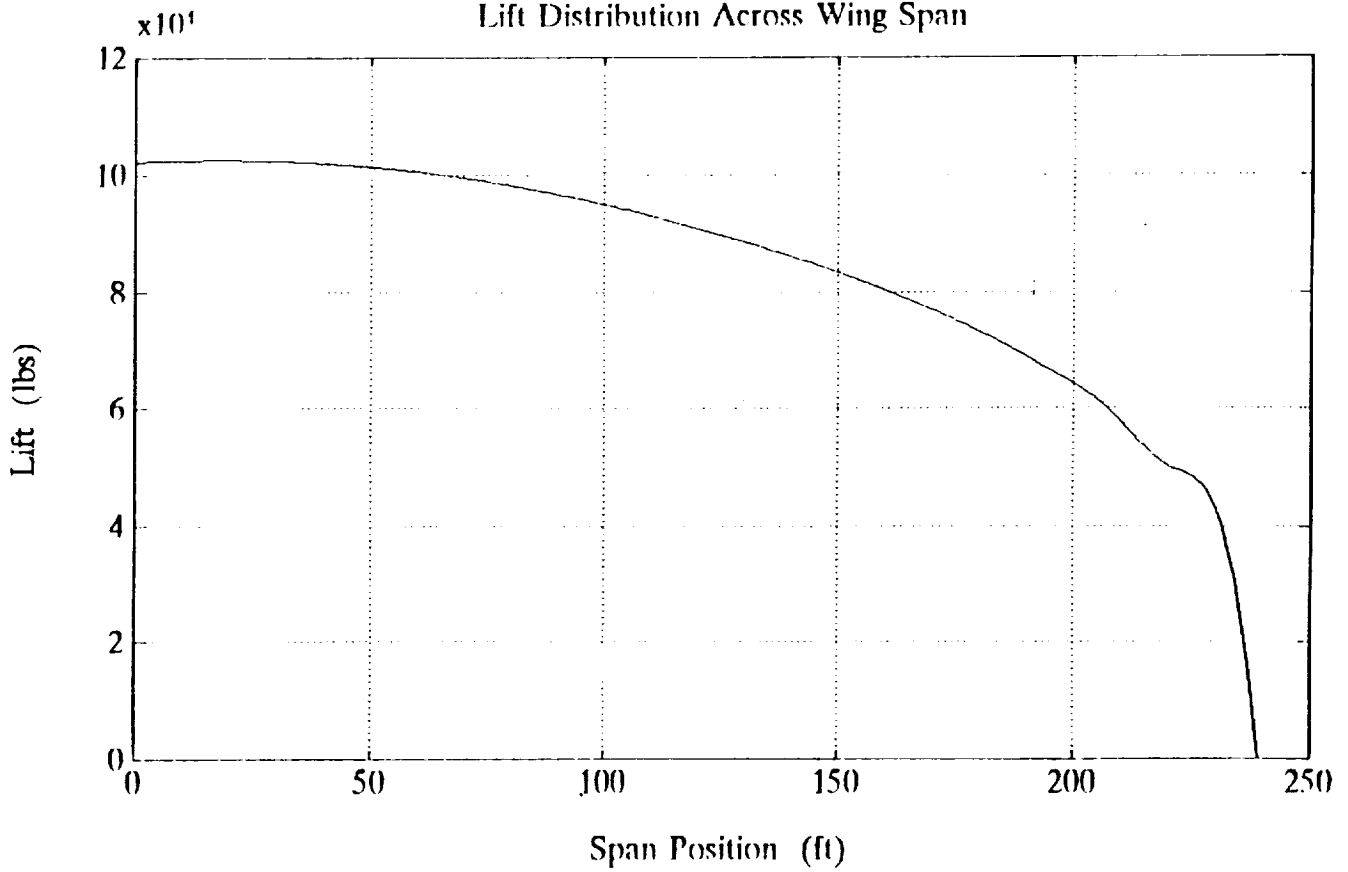

Figure V-3

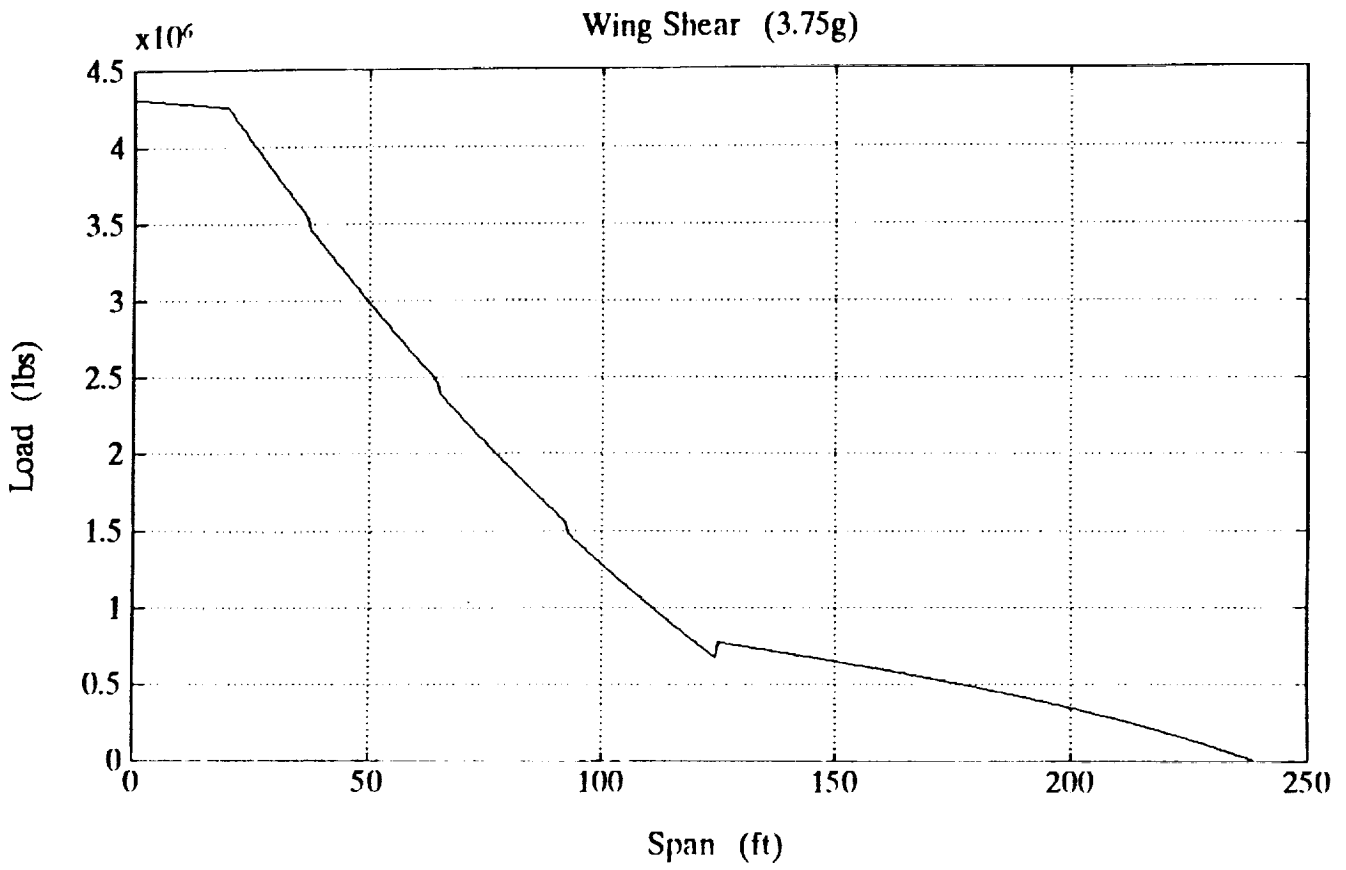

Figure V-4

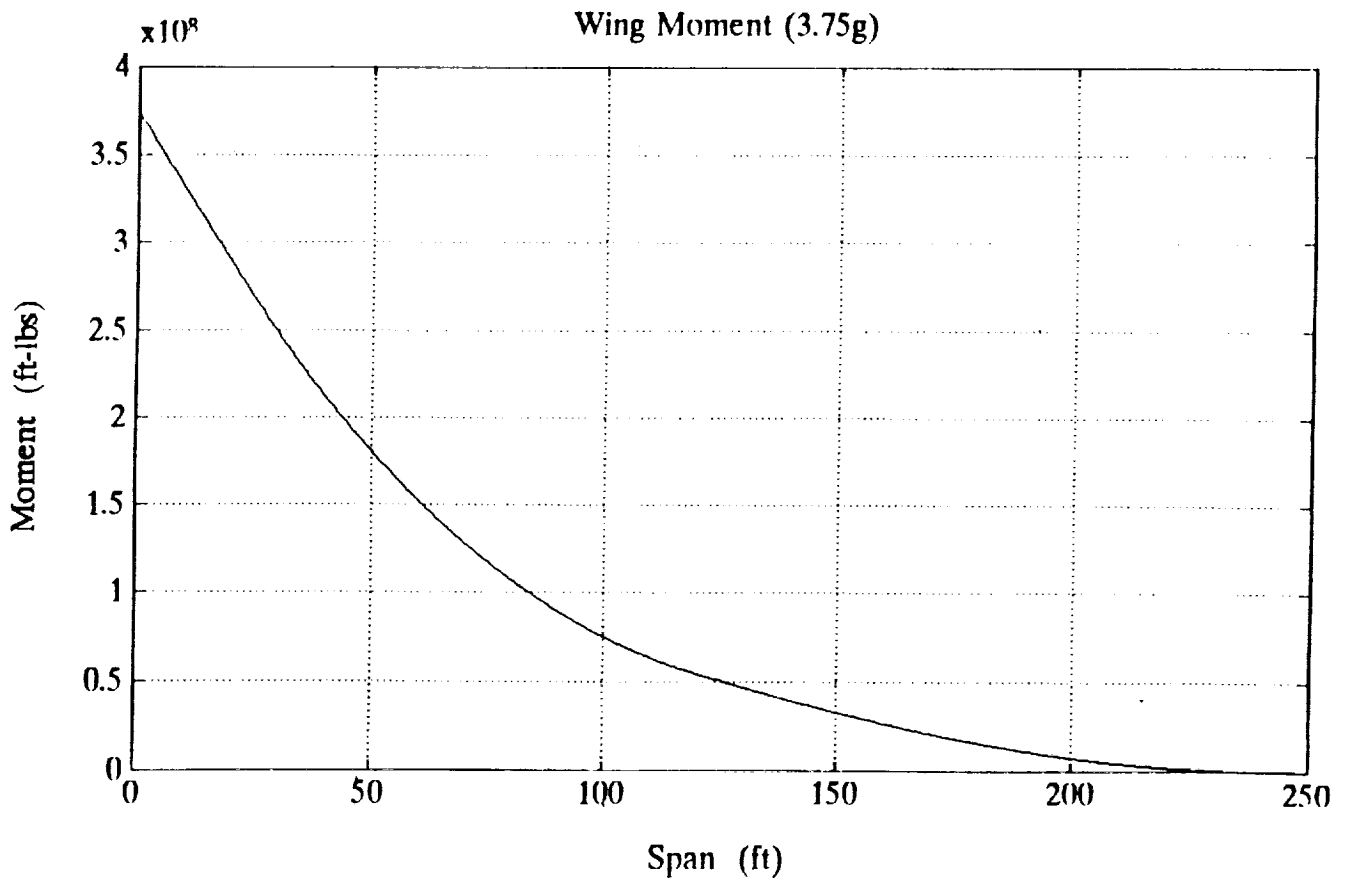
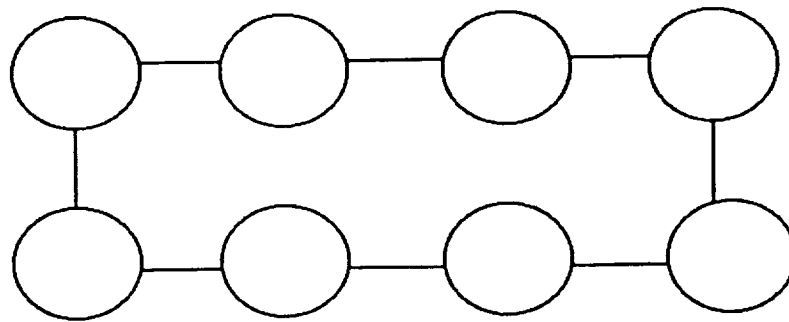

Figure V-5

## NODE ANALYSIS OF WING ROOT



**INITIAL AREA = 3.75 ft<sup>2</sup>**

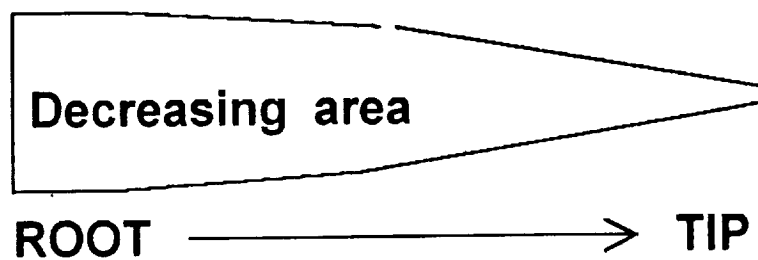

Figure V-6

### 5. Fuselage Structure

The fuselage was designed to optimize strength in all areas with a maximum occurring at the most critical areas such as the attachment points for the wings, canards, cargo bay doors and the landing gear. An attempt was made to utilize composites wherever possible in order to reduce the aircraft weight as much as feasible. This consideration contributes a great deal to the aircraft's cost, as more weight means higher cost. A more detailed analysis will be conducted in the next phase.

## B. LANDING GEAR

The main gear struts are located 167 feet from the datum (10 ft aft of the C.G. limit). To accommodate this location, a secondary frame was added aft of the rear spar frame with the landing gear loads transmitted forward to the rear wing spar. The nose gear was placed 120 ft forward of the main gear, 57 ft aft of the aircraft nose and mounted to the main trunnion of the aft side of the canard's rear spar.

These locations provided for a maximum static main gear load of 91.6% weight and a minimum 8.4% static nose gear load. This nose gear placement provided a 20.4% maximum static nose gear load when the aircraft is at its forward C.G. limit. These weight distributions follow the guidelines set by Ref(10). The nose gear dynamic load or max braking nose gear load was determined to be 27.3% during a 10 ft/sec<sup>2</sup> deceleration braking. The tipover angle is 54 degrees and the tip back angle is 13 degrees. These are within the limits set by Reference(10) of a tipover angle less than 63 degrees for land based aircraft and a tip back angle of 12-15 degrees for landing considerations. Figure V-7 is a schematic of rotation and tipover specification limits. Figure V-8 is a view of the gear placement on the aircraft.

The following information was used for tire selection:

Maximum gross weight	= 4,000,000 lb
Maximum main gear load	= 3,664,000 lb
Maximum nose gear load (static)	= 832,000 lb
Maximum nose gear load (dynamic)	= 1,000,000 lb
Maximum speed of aircraft on ground	= 175 mph

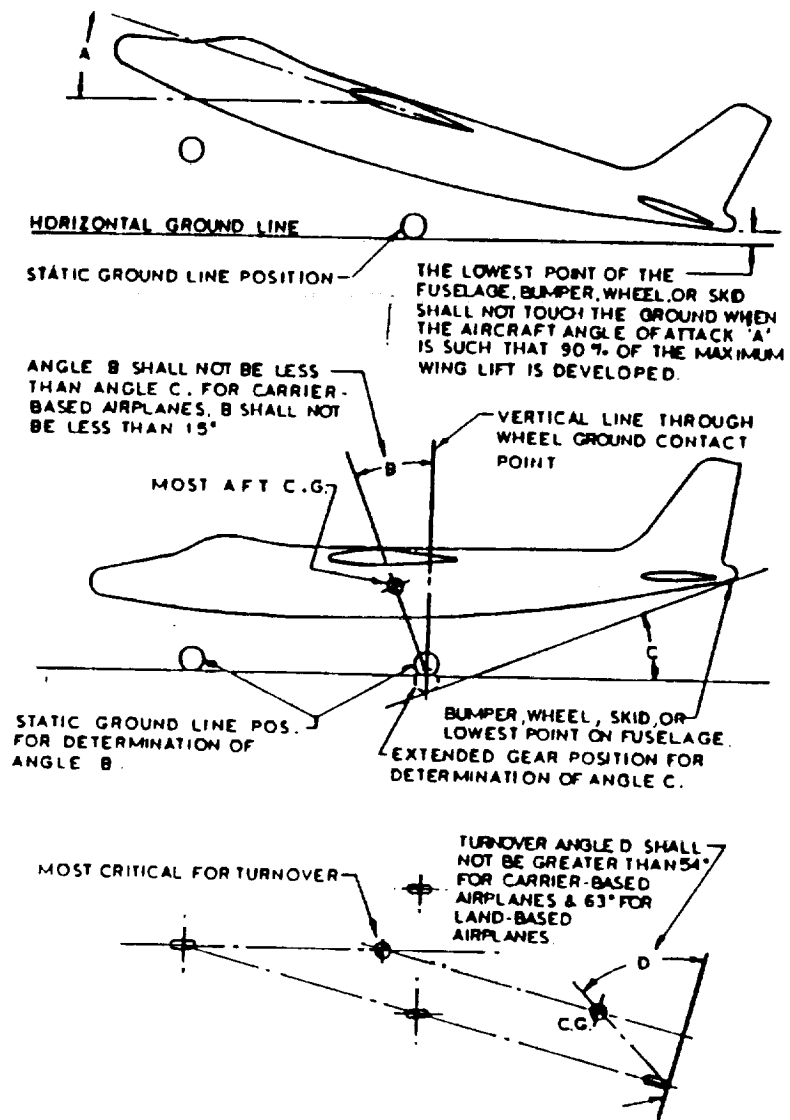

U.S. Navy landing gear layout requirements (source: U.S. Navy Specification SD-24J).

Figure V-7

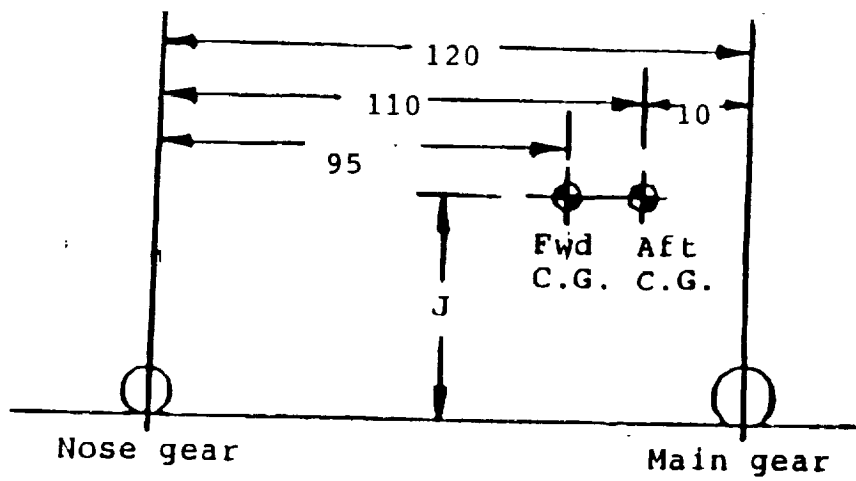

Diagram for nose landing gear load calculation.

Figure V-8

The tire size was calculated to be 50 X 20 inflated to 210 psi and capable of handling a load of 61,200 lbs at that pressure.

The main gear landing stroke was calculated using Reference (10) equations:

St = tire deflection under N times static load, ft

S = vertical wheel travel, ft

nt = tire efficiency, assumed to be 0.47

ns = shock strut efficiency assumed to be 0.80

N = landing gear load factor

N cg = load factor of the c.g.

W = aircraft weight, lb

L = lift, lb

V = sink speed, ft/sec

N c.g. = 1 + N (for FAR transport aircraft)

$$(St \times nt \times N \times W) + (S \times ns \times N \times W) = (W \times V^2 / 2g) + (W-L)(S+St)$$

These calculations result in a strut travel of 13.2 in. for the main gear during a 10 ft/sec sink rate and a 1.5 landing gear load factor. Due to the large gross weight of the aircraft, six main struts are needed each containing 10 tires, and two nose struts each having eight tires. Views of the landing gear are provided in Figure V-9.

Additional features of the landing gear include the following: double acting shock absorbers to improve load handling, a kneeling system to lower the fuselage to ease cargo loading, a crosswind positioning system that rotates the wheels 20 degrees left or right to enable the aircraft to land in a severe crosswind without last minute correction of the fuselage heading, and an auto-jacking system to facilitate tire replacement by eliminating required auxiliary equipment.

## Truck Configuration

Main Mounts

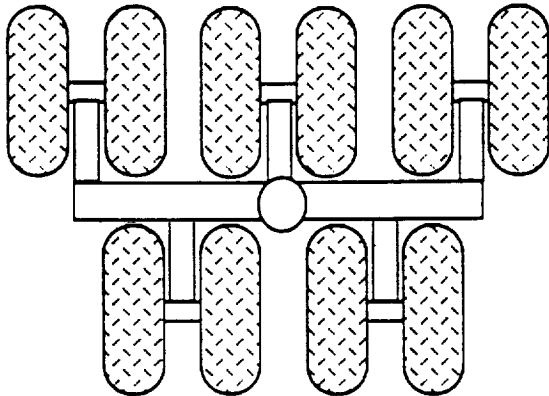

Nose Mounts

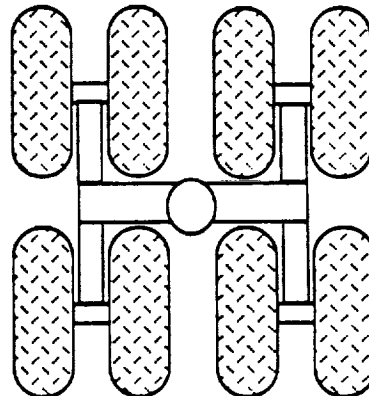

## Landing Gear Retraction Scheme

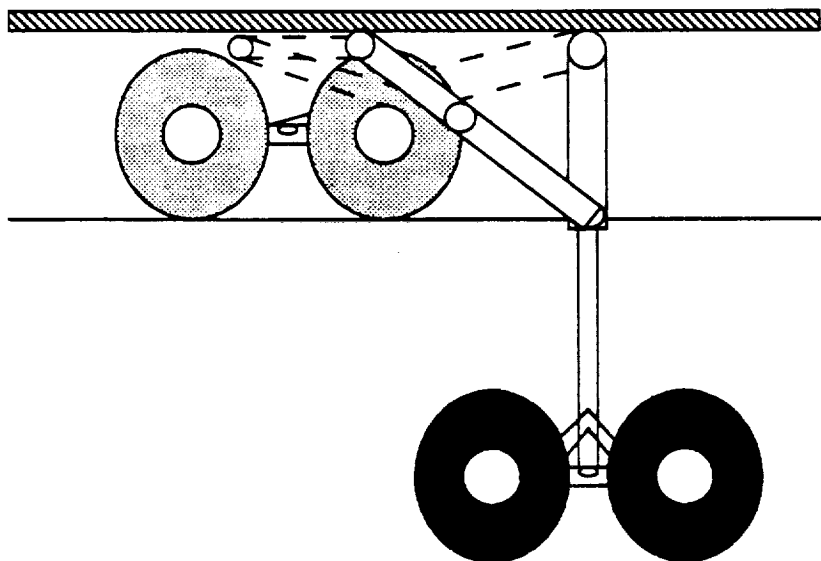

Figure V-9

## VI. PERFORMANCE

### A. PERFORMANCE CALCULATIONS

For all performance characteristics, it has been assumed standard day unless otherwise noted. Additionally, all results were generated for the clean configuration only with the obvious exception of the takeoff and landing phases of flight.

#### 1. Thrust Required

The thrust required for the Dumbo at four altitudes between sea level and 35,000 feet are shown in Figure VI-1. It is evident from the figure that variation of thrust required with altitude agrees with theory. The calculated thrust required curves were used to generate other performance characteristics such as power required and rate of climb.

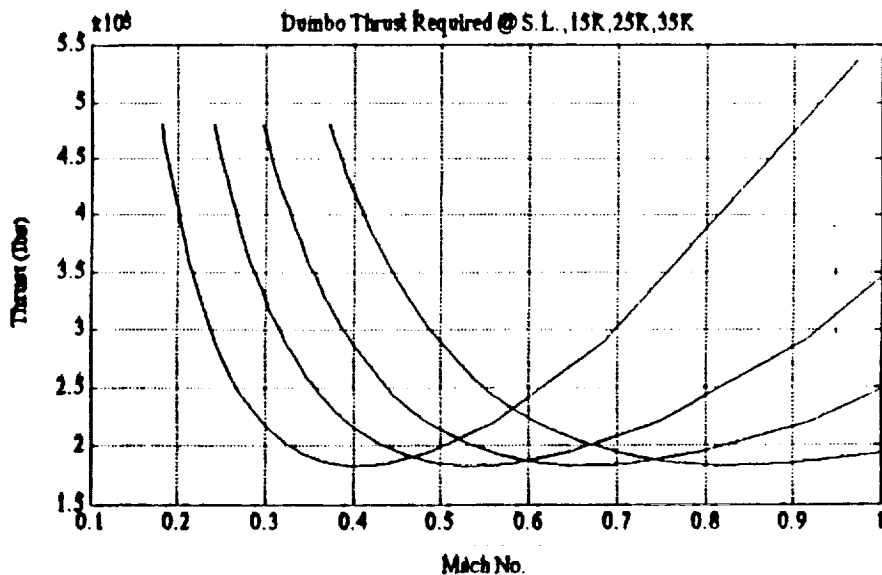
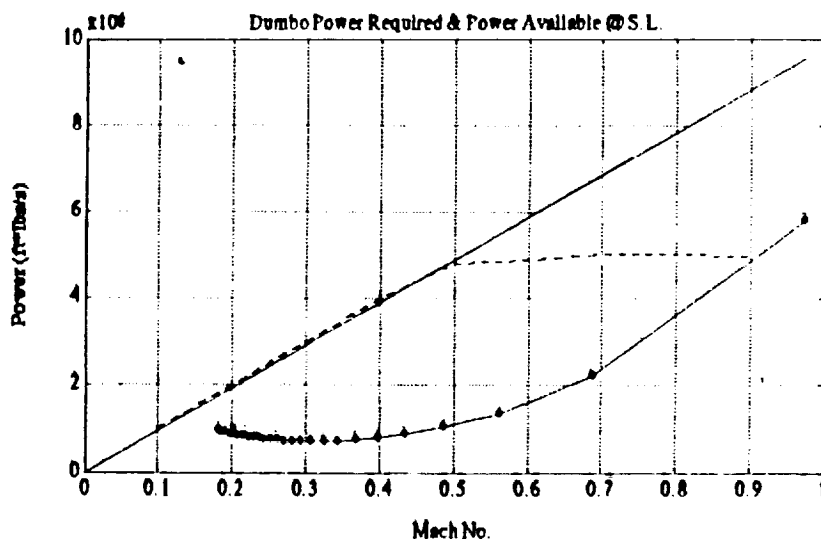

Figure VI-1

## 2. Power Required and Power Available

Dumbo power required and power available curves at sea level, 15,000 ft and 35,000 ft are shown in Figures VI-2, VI-3 and VI-4. Note that two power available lines are shown on each graph. The solid line represents the power available predicted by theory. The dashed line represents actual power available. It is clear that the theoretical prediction is valid only until approximately Mach equals 0.5. With increase in speed, the difference between theoretical and actual becomes quite significant. This is important because power available directly relates to excess power which in turn is instrumental in defining other performance characteristics such as rate of climb. Note also that the power required due to drag divergence is not included in this analysis.



KEY: 1) Power Required ==> '-o-'  
2) Power Available (Theoretical) ==> '-'  
3) Power Available (Actual) ==> '- -'

Figure VI-2

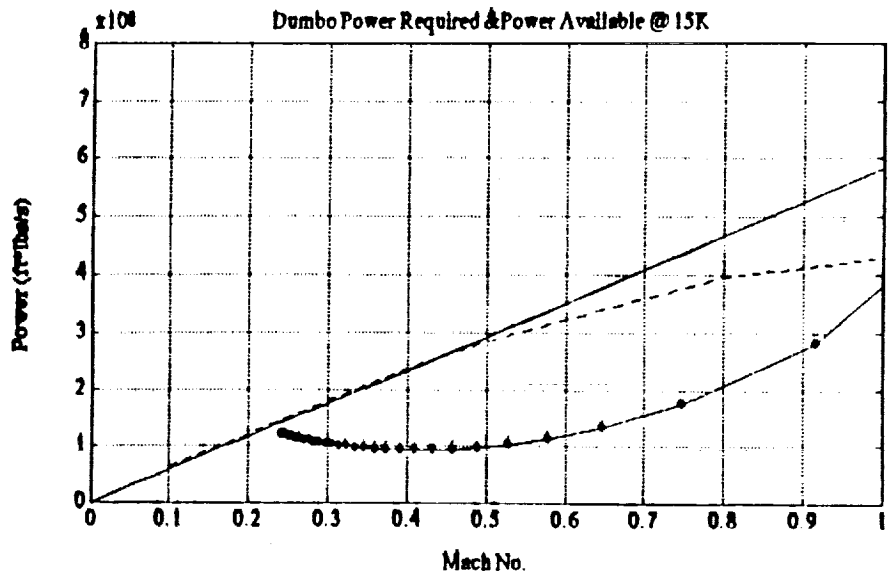

Figure VI-3

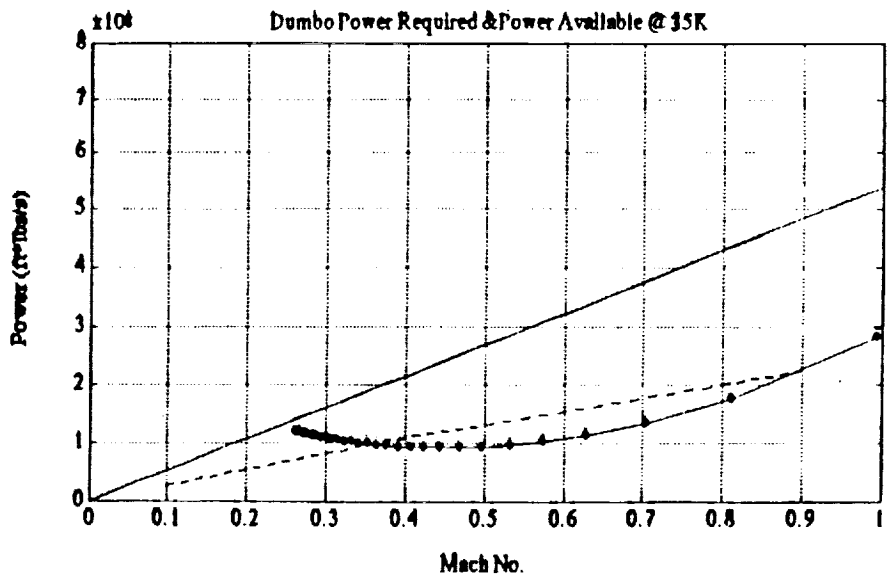
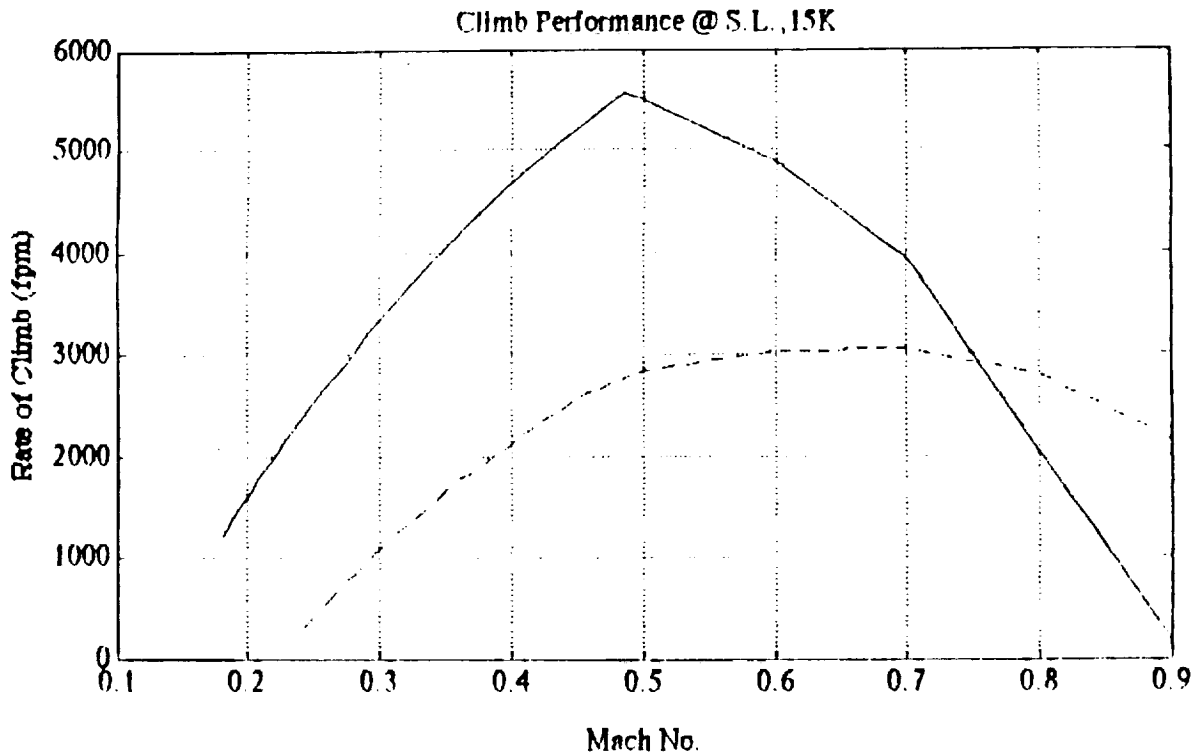

Figure VI-4

### 3. Climb Performance

Dumbo rate of climb at sea level and 15,000 ft. is shown in Figure VI-5. Rate of climb plots were generated at various altitudes until a service ceiling (rate of climb < 100 fpm) was established. It was determined the Dumbo aircraft will have a service ceiling of approximately 40,000 ft.



KEY: 1) Sea Level ==> '-'  
2) 15000 feet ==> '---'

Figure VI-5

#### 4. Range and Endurance

Range and endurance predictions are shown in Figures VI-6 and VI-7 respectively. The range plot shows variation in range with Mach number at four altitudes between sea level and 35,000 ft. The endurance plot shows variation in endurance with Mach number at 35,000 ft. only. While these predictions exceed the requirements of the RFP, they are considered necessary to meet the aggressive deployment schedule anticipated during a national emergency.

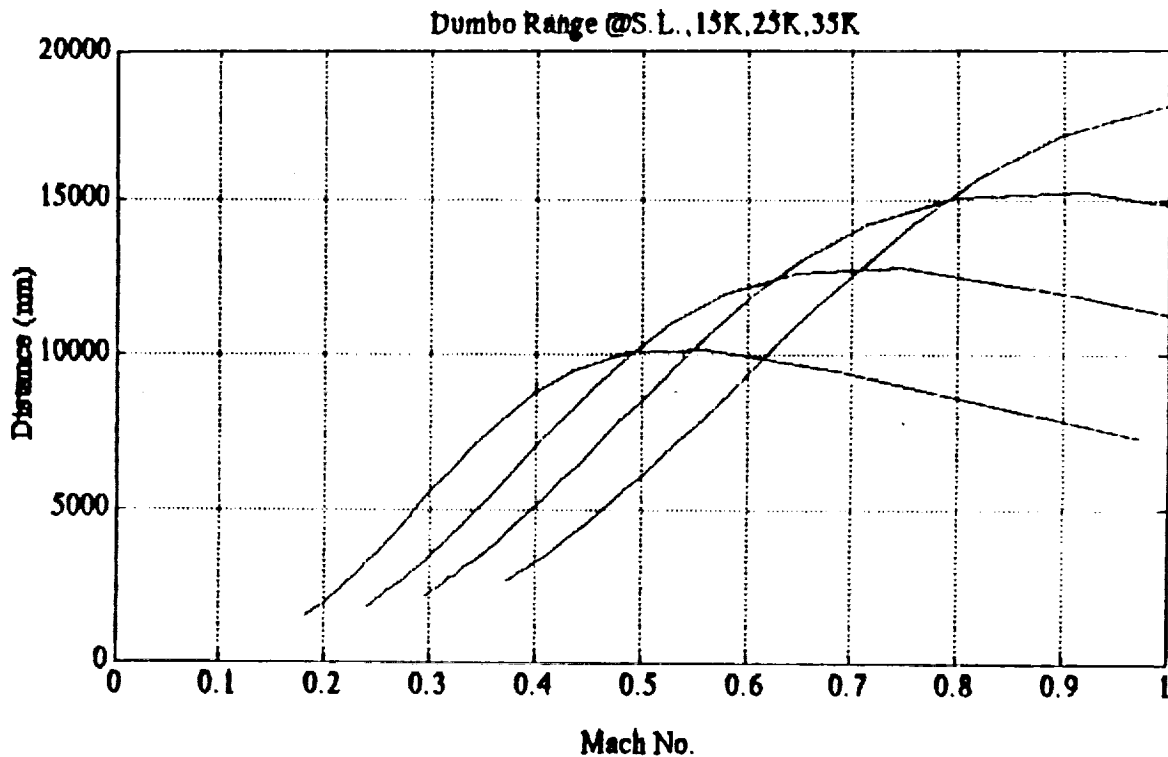

Figure VI-6

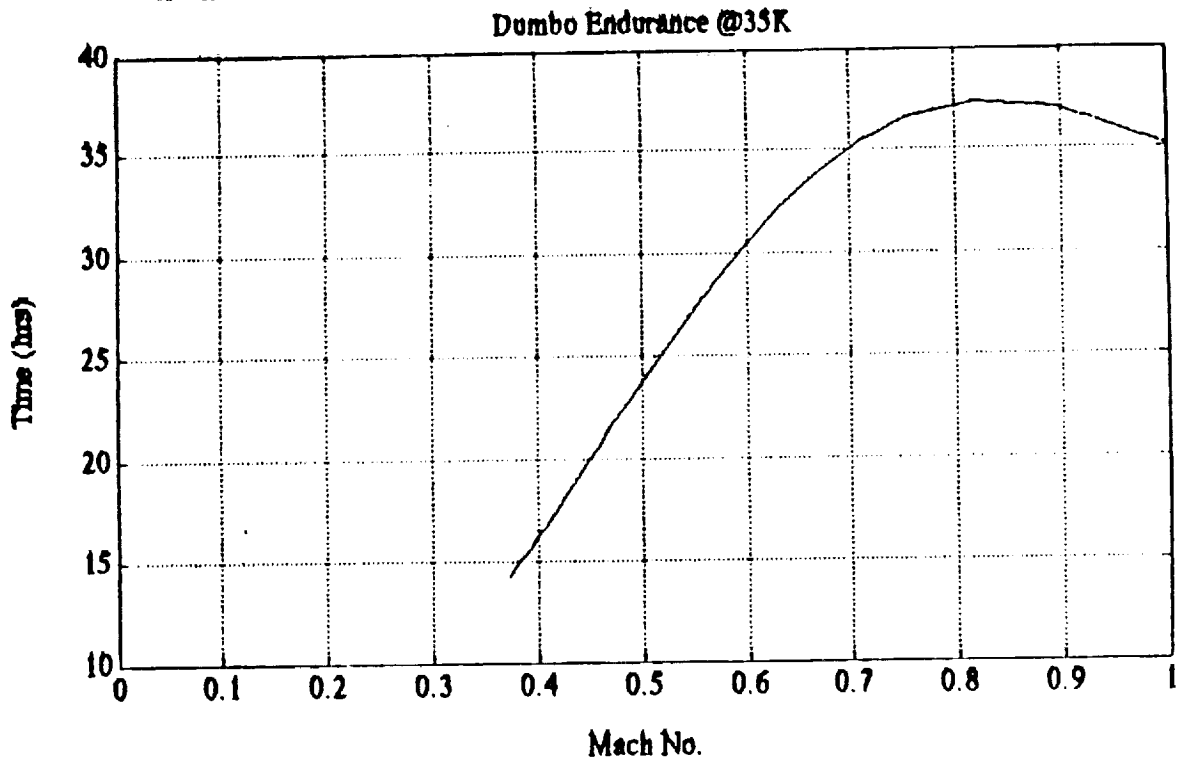

Figure VI-7

## 5. Takeoff and Landing

Because of the physical characteristics of the Dumbo aircraft, it was necessary to limit aircraft rotation to no more than 12 degrees. This angle of rotation is sufficient because best angle of climb was approximately 10 degrees. References (5), (21) and (23) provided schematics and distance equations necessary for takeoff and landing. Takeoff and landing schematics are shown in Figures VI-8 and VI-9 while takeoff and landing distances are shown in Tables VI-1 and VI-2.

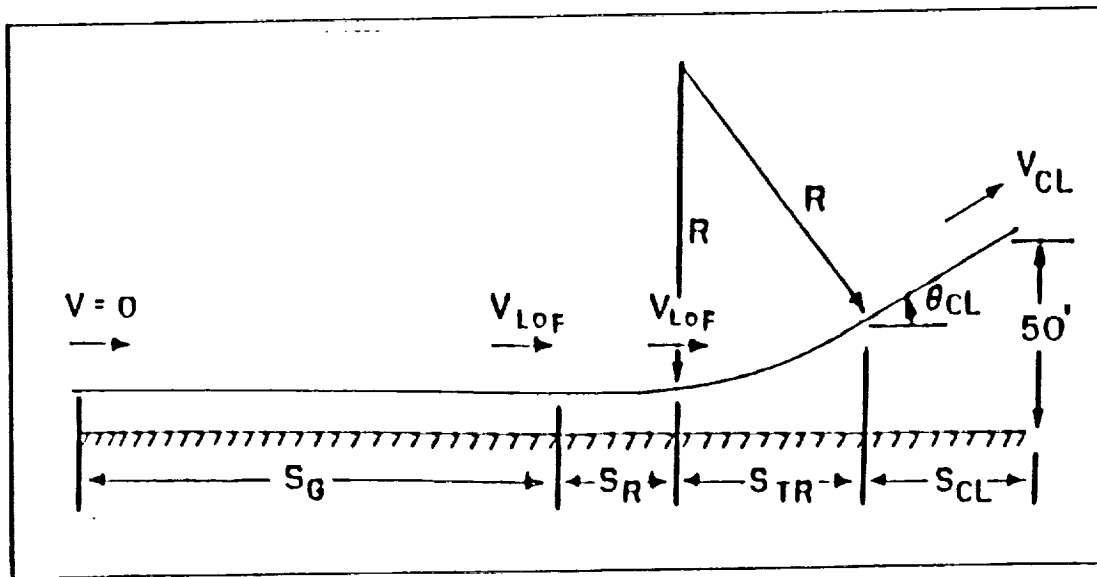

Figure VI-8

Takeoff Distances (GW= 4.0M LB)	STD Day	Hot Day (90° F)
$S_G$ (feet)	5819	6722
$S_R$ (feet)	720	720
$S_{TR}$ (feet) to 50'	1294	1325
$S_{Total}$ (feet)	7833	8767

Table VI-1

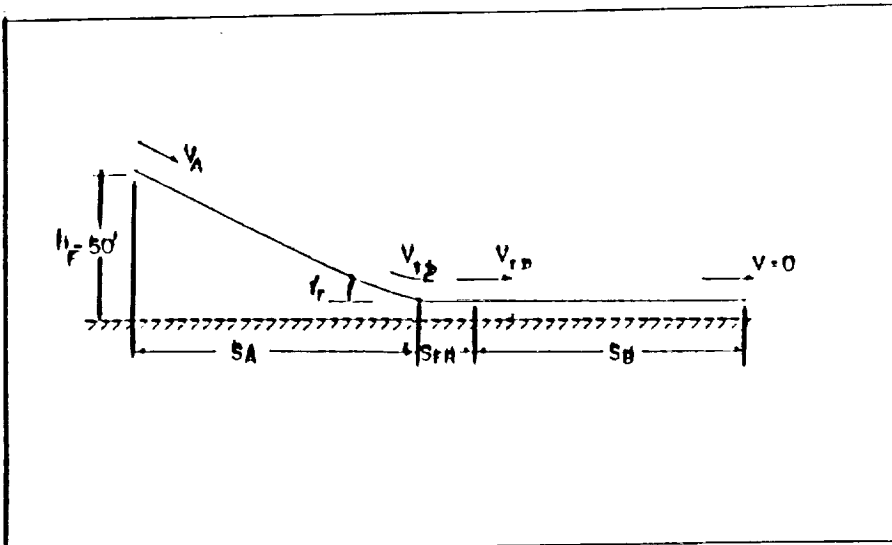

Figure VI-9

Landing Distances (GW= 3.0M LB)	STD Day	Hot Day (90° F)
$S_B$ (feet)	1321	1314
$S_{FR}$ (feet)	221	221
$S_B$ (feet) to 50'	7256	7861
$S_{Total}$ (feet)	8798	9396

Table VI-2

Another important characteristic during the takeoff phase is critical field length. Critical field length can be defined as the shortest runway that allows a safe abort with a single engine failure or continued takeoff at all time during the takeoff roll. The critical field length was computed to be 8,675 ft (std day) and 9,570 ft. (hot day).

## VII. STABILITY AND CONTROL

### A. INTRODUCTION

The stability and control analysis combines many elements of the design process. These include: the physical sizing, configuration, control surfaces, aerodynamic and structural design. All of these factors must be determined prior to completing a thorough static and dynamic stability analysis. The analysis itself determines whether any redesign is necessary to ensure stability and controllability during all flight conditions. The following assumptions were made:

- Linearized, small perturbation theory.
- Small aircraft deviations about a steady flight condition.
- No coupling between the longitudinal and lateral equations of motion.

The equations of motion used are set forth in Reference (20). The stability and control derivatives were estimated from procedures set forth in Reference (10), (11) and (18). The derivatives required are listed in Table VII-1a and b and are shown as compared to the C-5A cargo aircraft.

### B. STATIC STABILITY

#### 1. Longitudinal

Longitudinal stability requires a positive zero lift pitching moment,  $C_{m_0}$ , and a negative pitching moment,  $C_{m_\alpha}$ .  $C_{m_0}$  must be positive in order for the aircraft to be trimmed at positive angles of attack. A negative  $C_{m_\alpha}$  ensures a restoring moment to the aircraft when either an upward or downward gust is encountered. Both conditions have been met for this design.

	Mach = 0.2	Mach = 0.77	C-5A
$C_L$	2.09	.675	1.29
$C_D$	.182	.0307	.145
$C_{L\alpha}$	5.04	6.57	6.08
$C_{L\alpha\alpha}$	.843	.355	.622
$C_{m\alpha}$	-.703	-.916	-.827
$C_{m\alpha^2}$	.003	.071	-8.3
$C_{m\alpha\alpha}$	0	0	-
$C_{mq}$	-6.76	-8.82	-23.2
$C_{Lq}$	4.83	6.31	-
$C_{L\dot{\alpha}}$	.41	.38	.385
$C_{L\dot{\alpha}\alpha}$	-.018	-.014	-
$C_{m\dot{\alpha}}$	-1.1	-1.0	-1.6
$C_{L\alpha\dot{\alpha}}$	0	0	0

LONGITUDINAL STABILITY DERIVATIVES  
Table VII-1a

	Mach = 0.2	Mach = 0.77	C-5A
$C_{y\beta}$	- .22	- .21	- .77
$C_{yP}$	.51	.164	-
$C_{yr}$	.26	.26	-
$C_{j\beta}$	- .209	- .062	- .123
$C_{jP}$	- .55	- .53	- .458
$C_{jr}$	522	.169	.29
$C_{n\beta}$	.087	.009	.075
$C_{nP}$	- .26	- .084	- .098
$C_{nr}$	- .09	- .012	- .293
$C_{y\dot{\beta}}$	.073	.068	.211
$C_{y\dot{P}}$	0	0	- .0044
$C_{j\dot{\beta}}$	.008	.021	.0209
$C_{j\dot{P}}$	.001	.0014	.089
$C_{n\dot{\beta}}$	- .018	- .017	- .106
$C_{n\dot{P}}$	0	0	.0091

LATERAL-DIRECTIONAL STABILITY DERIVATIVES  
Table VII-1b

Static margin is also an important estimator of longitudinal static stability. In most designs, it is desirable to have a stick fixed static margin of approximately 5%. For this design, there is a 13.8% static margin.

## 2. Lateral-Directional

Lateral-Directional stability requires a positive  $C_n\beta$  and a negative  $C_l\beta$ . A positive  $C_n\beta$  ensures a restoring yawing moment when the aircraft is subjected to a sideslip angle. A negative  $C_l\beta$  ensures stability when disturbed during turns. The tail and rudders were sized adequately to meet these requirements.

## C. DYNAMIC STABILITY

### 1. Longitudinal

Table VII-2 lists the results obtained from the short-period and long period (phugoid) approximations, and are compared with MIL-F-8587C requirements for a class III, category B and C aircraft. At Mach = 0.2, the aircraft was found to be stable, but exhibited a low natural frequency. At Mach = 0.77, the short-period characteristics show a high natural frequency and low damping. The phugoid mode damping was also too low. The responses exhibit a high degree of oscillation out to ten seconds.

	Mach = 0.2	Mach = 0.77	MIL-F-8785C
Short Period roots	$-.351 \pm .5881i$	$-.4355 \pm 1.1789i$	negative
S.P. damping	.5125	.3465	$0.35 < \zeta < 1.3$
S.P. nat. frequency	.6849	1.2568	$0.7 < \omega < 1.2$
Long Period roots	$-.012 \pm .1912i$	$-.002 \pm .0608i$	negative
L.P. damping	.0626	.0329	$\zeta > 0.4$
L.P. nat. frequency	.1916	.0608	-

Table VII-2

Short-Period Step Response to Elevator Input

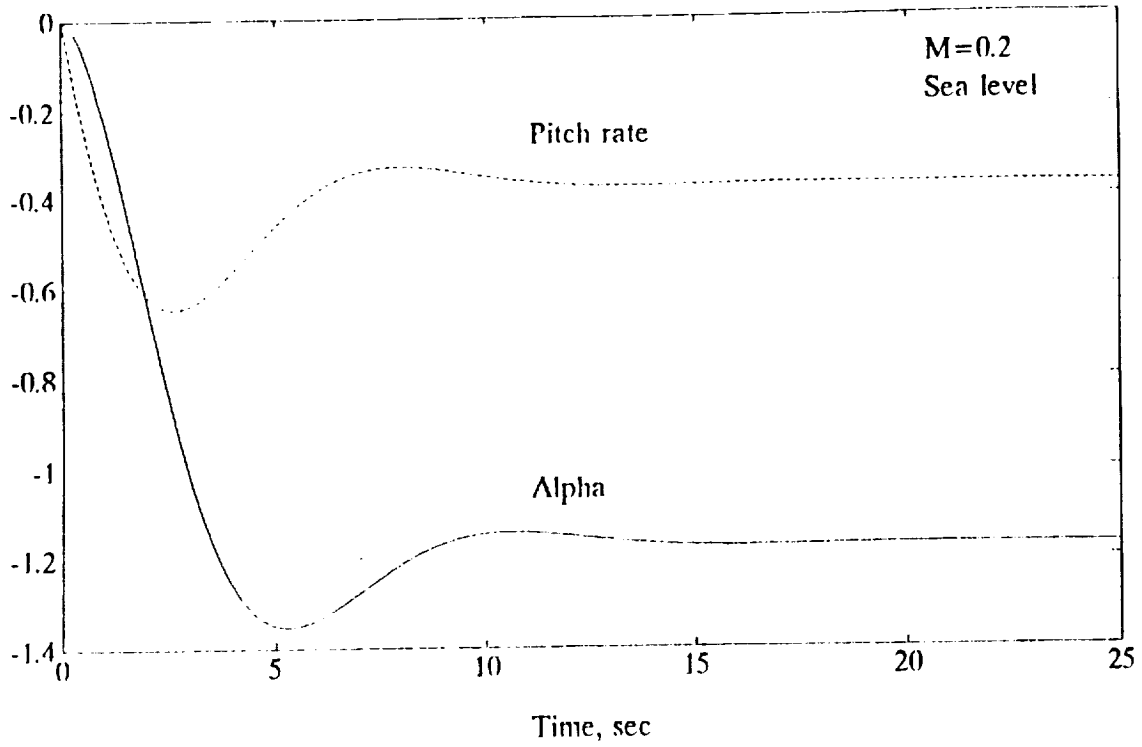

Figure VII-1a

Short-Period Step Response to Elevator Input

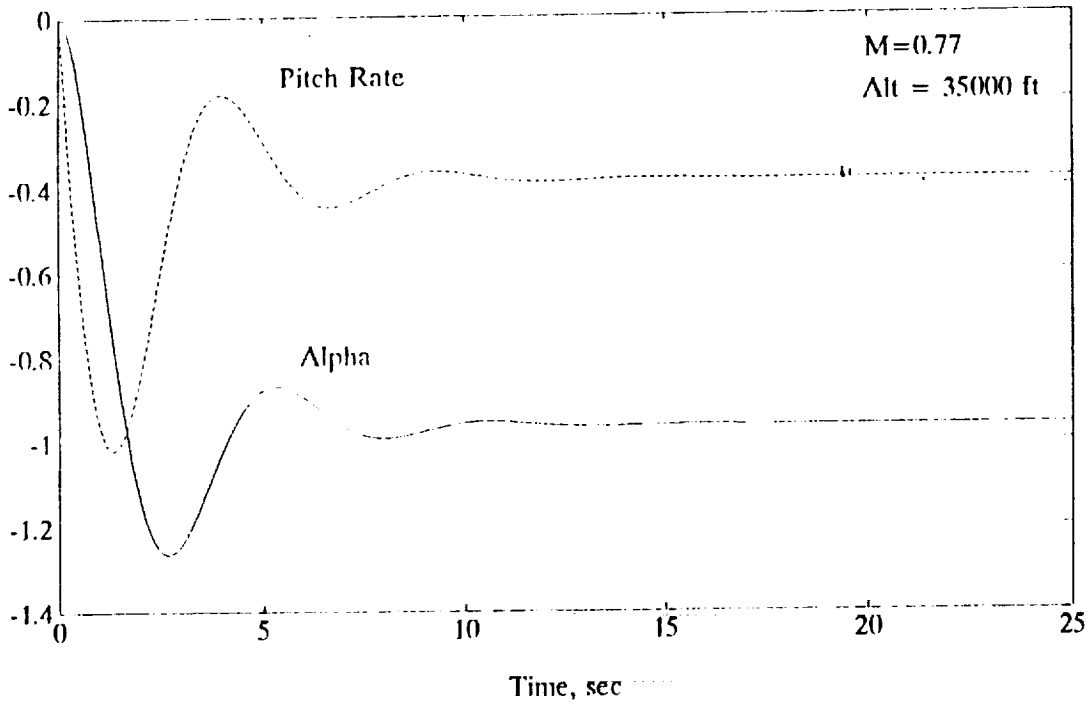

Figure VII-1b

Plots of alpha and pitch rate responses are shown in Figures VII-1a and b.

## 2. Lateral-Directional

Table VII-3 lists the results obtained from the Lateral-Directional stability analysis and the Dutch-Roll Approximation. At Mach = 0.2, the roll time constant proved to be too large. As can be seen from Figure VII-2a, response is very oscillatory out to 20 seconds for both yaw angle and roll rate. At Mach = 0.77, Figure VII-2b shows both responses to be marginally stable. The natural frequency and damping values are both too low to meet mil-standard requirements.

	Mach = 0.2	Mach = 0.77	MIL-F-8785C
Dutch-Roll roots	$-.14+.5234i$	$-.0031+.2738i$	negative
D.R. damping	.2594	.0113	$\zeta > .08$
D.R. nat. frequency	.5419	.2739	$\omega > .4$
Roll Response root	-.6888	-.8138	-
Roll nat. frequency	.6888	.8138	-
Roll time constant	1.45	1.23	<1.4
Spiral root	.0266	.0019	-
Spiral time constant	26.06	364.8	>12

Table VII-3

## D. STABILITY AUGMENTATION

### 1. Introduction

Due to the long settling time, and high speed cruise marginal stability, it was decided to employ stability augmentation about all three axes using state variable feedback design techniques.

Dutch-Roll Approximation Response due to Rudder Impulse

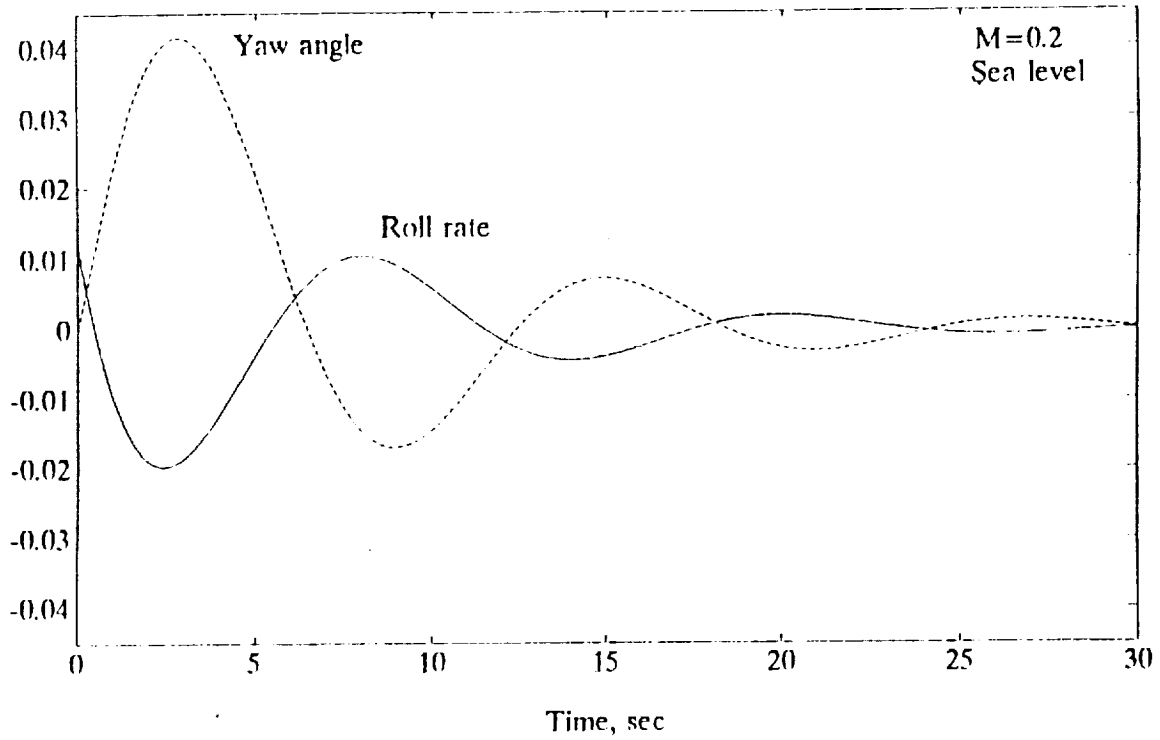

Figure VII-2a

Dutch-Roll Approximation due to Rudder Impulse

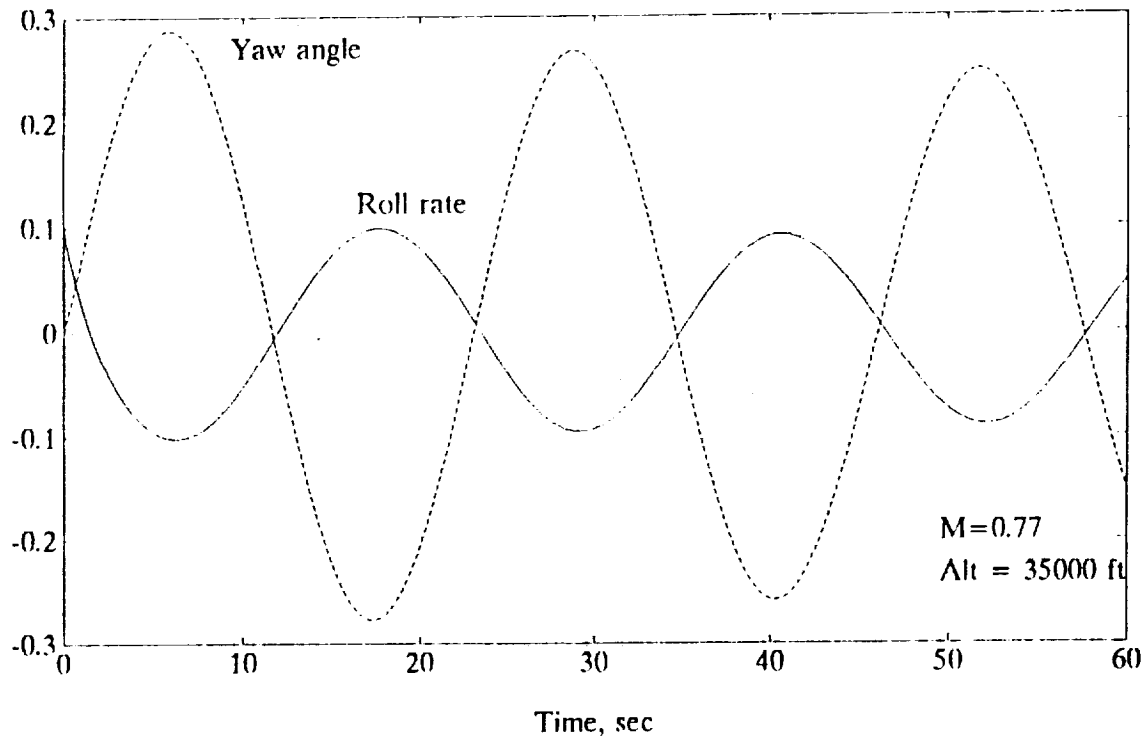

Figure VII-2b

## 2. Longitudinal

Flying qualities were enhanced in both short-period and phugoid modes with new pole locations as shown in Table VII-4. All deficiencies were corrected with these new locations. Response is much quicker with no oscillations. Figures VII-3a through d show the reduced settling time and more than 50% reduction in peak overshoot. This was achieved with relatively small feedback gain amplitudes. Augmentation is such that flying qualities remain consistent at both high and low speeds.

	Mach = 0.2 Unaugmented	Mach = 0.2 Augmented	Mach = 0.77 Unaugmented	Mach = 0.77 Augmented
S.P. roots	$-.351+.588i$	$-.9+.7i$	$-.435+1.179i$	$-.95+.7i$
S.P. damping	.5125	.7894	.3465	.8051
S.P. nat. freq.	.6849	1.1402	1.2568	1.18
L.P. roots	$-.012+.1912i$	$-.012+.19i$	$-.002+.0608i$	$-.004+.067i$
L.P. damping	.0626	.0626	.0329	.0596
L.P. nat. freq.	.1916	.1916	.0608	.0671

Table VII-4

Short-Period Step Response: Unaugmented vs. Augmented

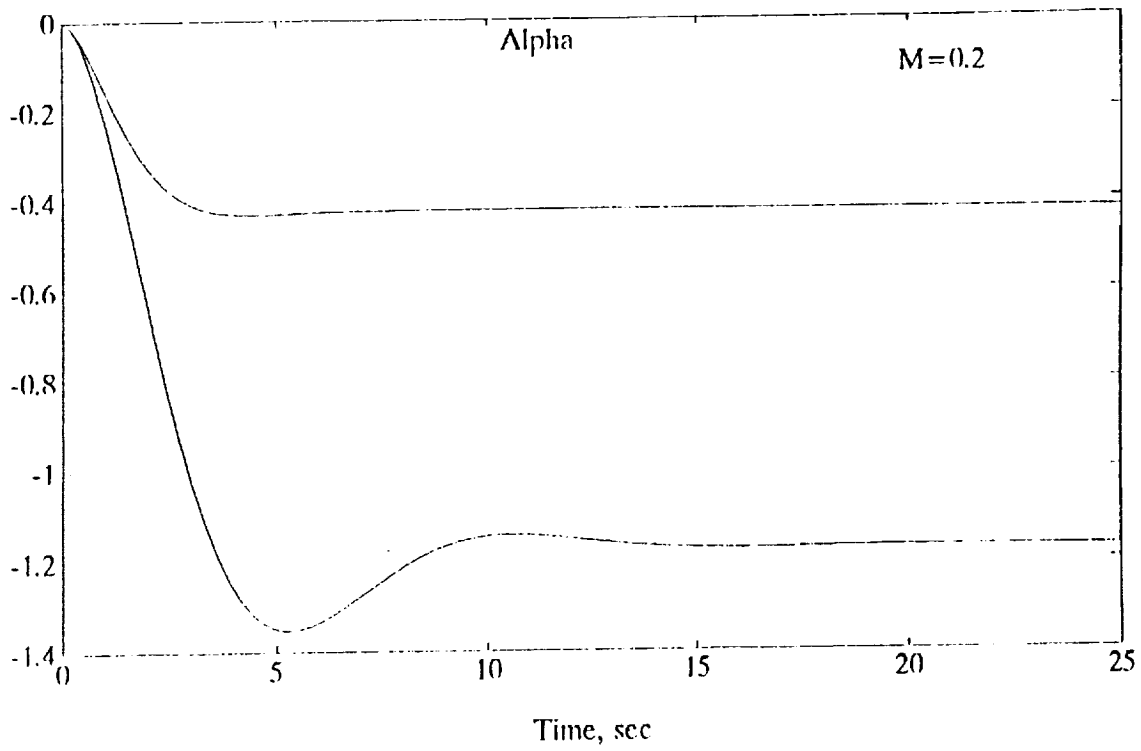

Figure VII-3a

Short-Period Step Response: Unaugmented vs. Augmented

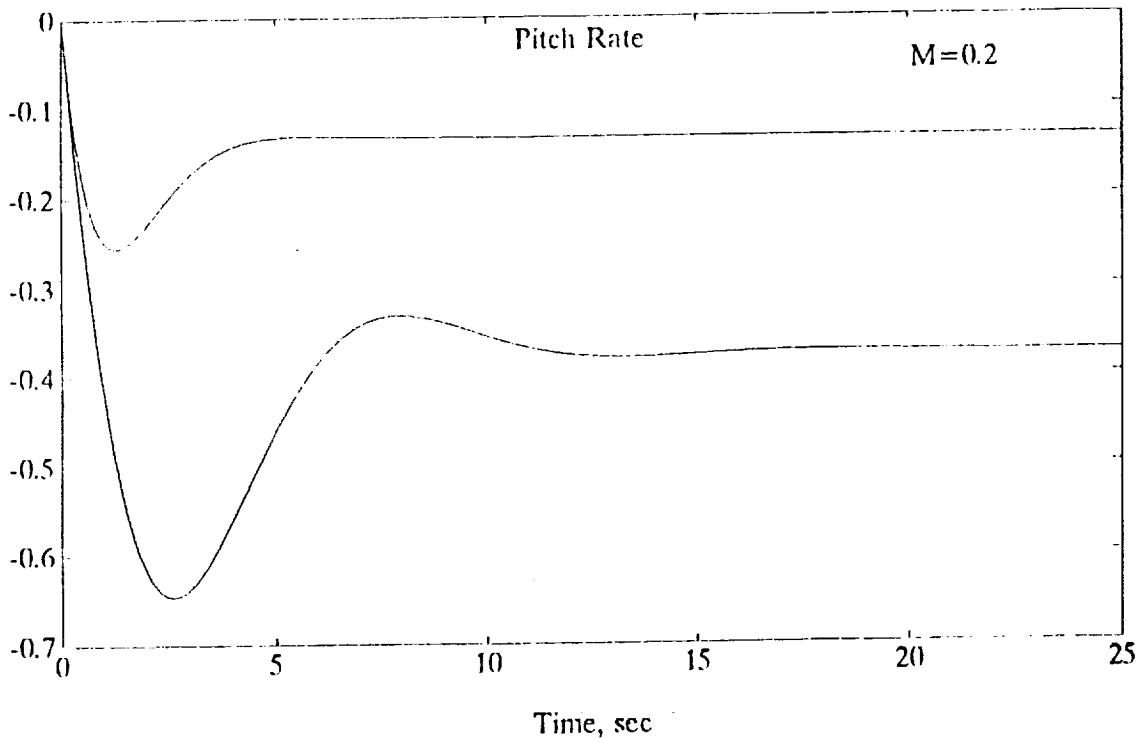

Figure VII-3b

Short-Period Step Response: Unaugmented vs. Augmented

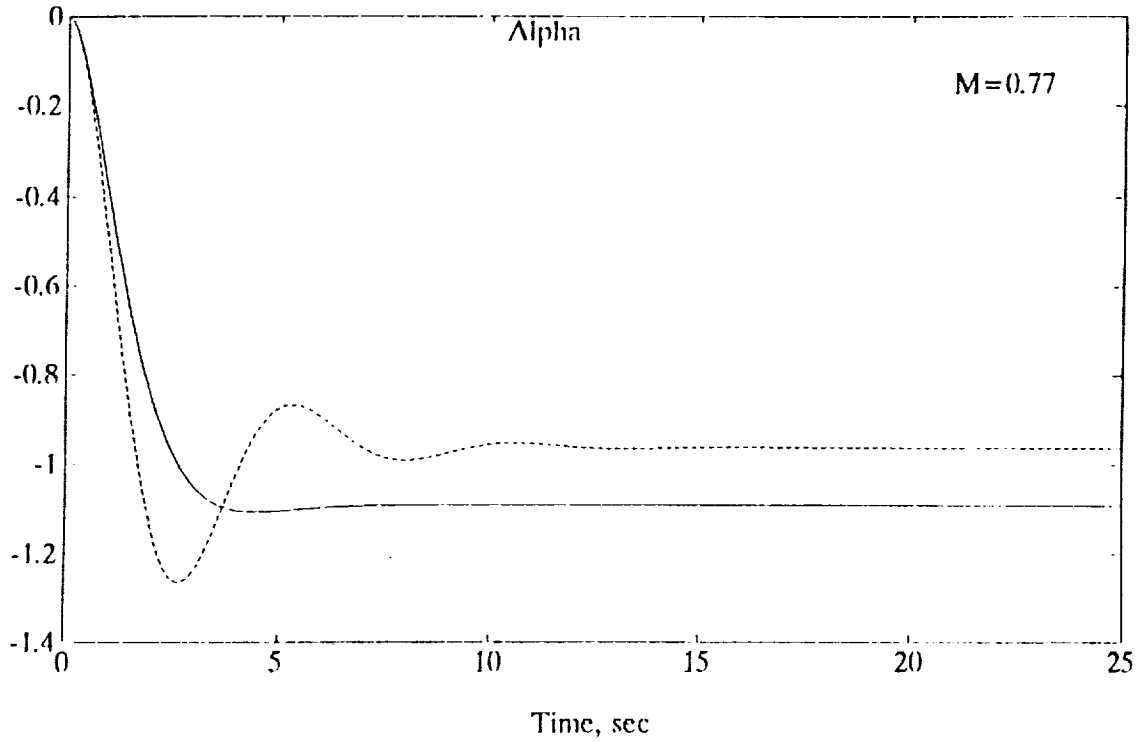

Figure VII-3c

Short-Period Step Response: Unaugmented vs. Augmented

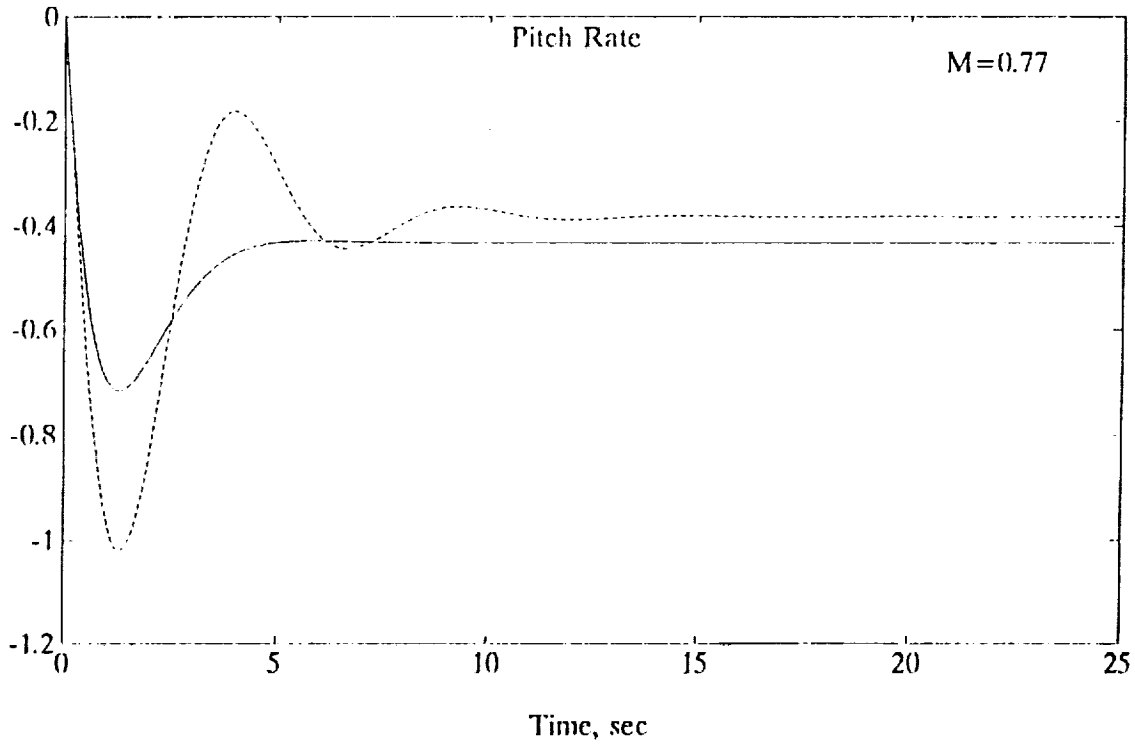

Figure VII-3d

### 3. Lateral-Directional

As with longitudinal augmentation, lateral-directional augmentation was performed to achieve consistent flying qualities at both low and high speeds. Table VII-5 lists the new pole locations and new parameters. All deficiencies were corrected. Figures VII-4a and b compare the yaw angle response to a rudder impulse for the unaugmented and augmented systems.

	Mach = 0.2 Unaugmented	Mach = 0.2 Augmented	Mach = 0.77 Unaugmented	Mach = 0.77 Augmented
D.R. roots	$-.14+.52i$	$-1.5+.6i$	$-.0031+.27i$	$-1+.95i$
D.R. damping	.2594	.9285	.0113	.725
D.R. nat. freq.	.5419	1.6155	.2739	1.3793
Roll root	$-.6888$	-2	$-.8138$	$-.8138$
Roll nat. freq.	.6888	2	.8138	.8138
Roll time constant	1.45	.5	1.23	1.23

Table VII-5

Yaw Angle Response: Unaugmented vs. Augmented

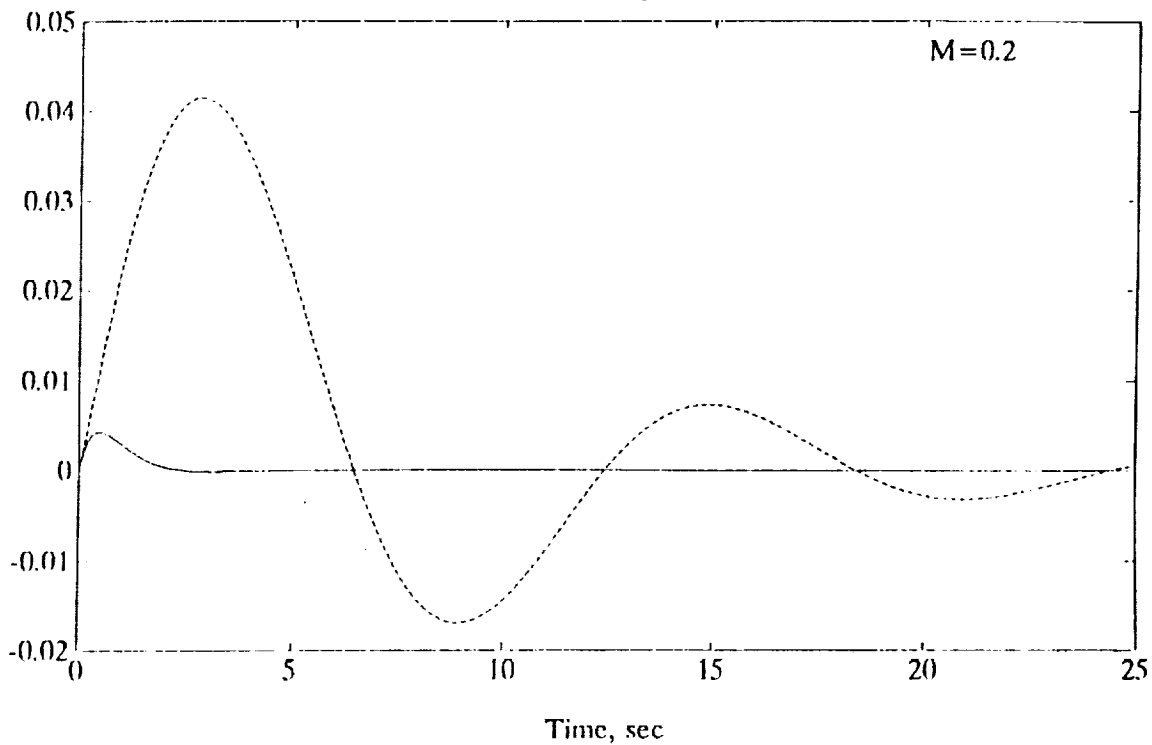

Figure VII-4a

Yaw Angle Response: Unaugmented vs. Augmented

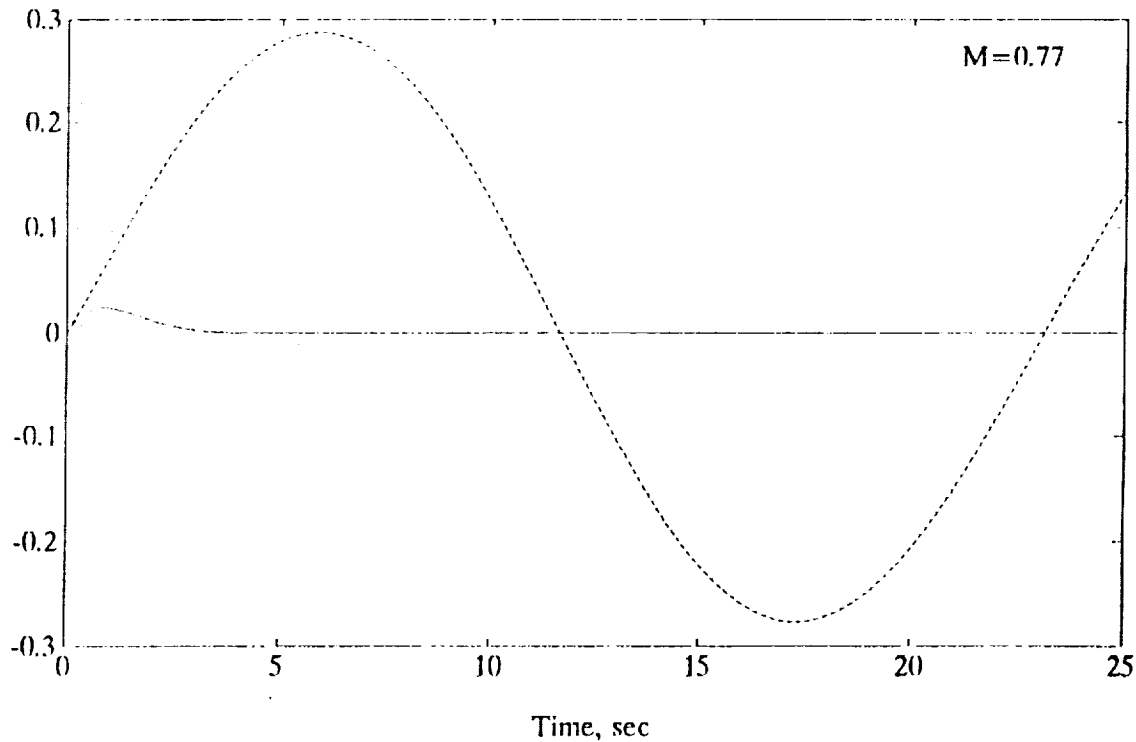

Figure VII-4b

## VIII. AIRCRAFT SYSTEMS

### A. DESIGN GOALS

The design goals set for the systems engineering of the Dumbo aircraft centered primarily around meeting or exceeding RFP requirements and maximizing usage of off the shelf technologies. This approach provided maximum advantages in procurement, maintainability, cost, reliability, weight and operational integration into the fleet. The systems engineering of the Dumbo aircraft is broken down into six categories: hydraulic, electrical, environmental, auxiliary power, fuel and cargo systems.

### B. SYSTEMS

#### 1. Hydraulic System

Three separate systems provide Dumbo with hydraulic power. They are the flight control system (FC), utility one (U1) and utility two (U2).

The flight control system provides power to all flight controls, both rudder segments, all main wing leading/trailing edge control surfaces, and canard wing leading/trailing edge control surfaces, through the primary half of a dual tandem actuator. The dual tandem actuator also receives power from one of the utility systems. The FC system has its own reservoir and accumulator, both located in the upper fuselage main wing root area. The flight hydraulic system is energized by six engine-driven pumps, one on each of Dumbo's engines, and any two are capable of meeting the maximum possible system demand.

U1 provides power to approximately half of the flight controls including the upper rudder segment, the inner segment of the canard's

leading/trailing edge control surfaces and the outer three segments of the main wing's leading /trailing edge control surfaces. The remaining flight controls receive power through U2. U1 and U2 both provide power to the following systems through dual tandem actuators: aft ramp, aft clam shell doors, nose visor, nose ramp, upper deck ramp, landing gear steering and wheel brakes. The U1 system also provides power to extend and retract the landing gear. In an emergency, the landing gear can be extended by pressurizing the extension system with U2. The U2 system provides power to the landing gear kneeling system. Braking is accomplished by both the U1 and U2 systems supplying half the wheels each per strut. U1 is powered by a pump on each of the odd numbered engines, any two of which are capable of meeting the maximum system demand, and by APU #2 which can meet all the system's demand alone. U2 is similarly supplied with power from even numbered engines and APU #1. U1 and U2 each have their own reservoir and accumulator located in the vicinity of the APU associated with the respective system.

All three systems operate at 5000psi and are equipped with appropriate level and pressure sensing instruments that are relayed to the cockpit. The three systems are configured so that loss of any one system should have virtually no impact on the aircraft, and with the loss of any two systems, control of the aircraft can be maintained. Future control analysis will determine if the flight controls have been optimally split between U1 and U2.

Hydraulic schematic is shown in Figure VIII-1.

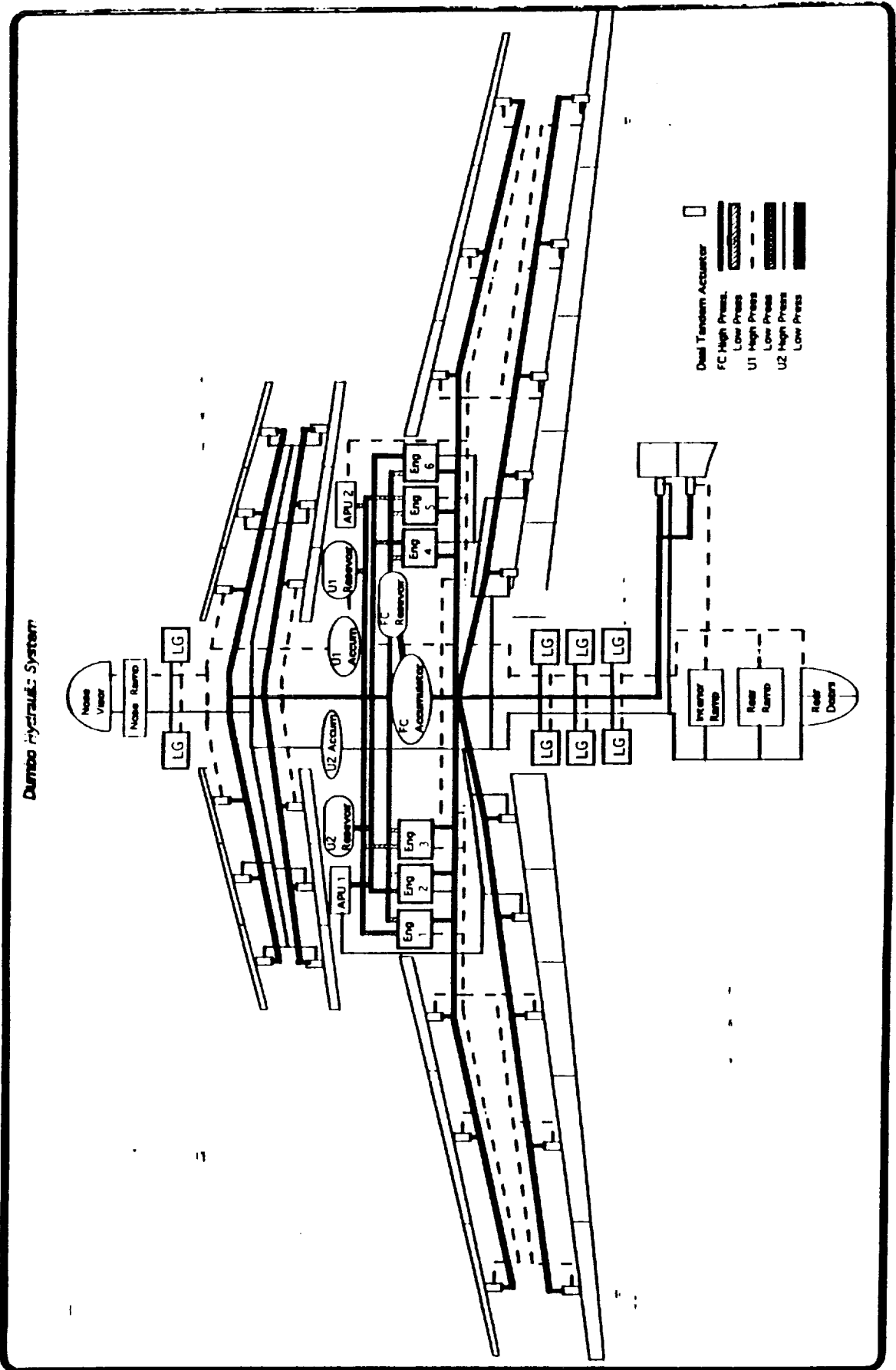

Figure VIII-1

## 2. Electrical System

The electrical system consist of four 100 KVA generators, one on each of the four inner engines, two transformer rectifiers, batteries and a 50 KVA generator on each of the APU's for emergency and ground power.

The primary power sources are the AC generators, any two of which could carry the entire load in flight. Power distribution is broken down as shown in Figure VIII-2. Each generator has it's own protection relay automatically disconnecting a faulty generator. A bus tie relay automatically prevents loss of power in the event both generators on the same side drop off line.

D.C. power is provided by two transformer rectifiers, either of which satisfy all of the D.C. power requirements. A D.C. bus tie relay prevents power loss from D.C. buses in the event of a transformer rectifier failure. A battery can supply power to the essential D.C. buses in the event of a total power failure, but is primarily present to start the APU's. The battery is continually trickle charged when A.C. power is available.

Whenever electrical power demands exceed available power, non-essential busses are automatically shed, but can be manually brought back on line. An external power receptacle is provided in the side of the fuselage forward of the canard.

A general schematic of the electrical system is shown in Figure VIII-2.

# Dumbo Electrical System

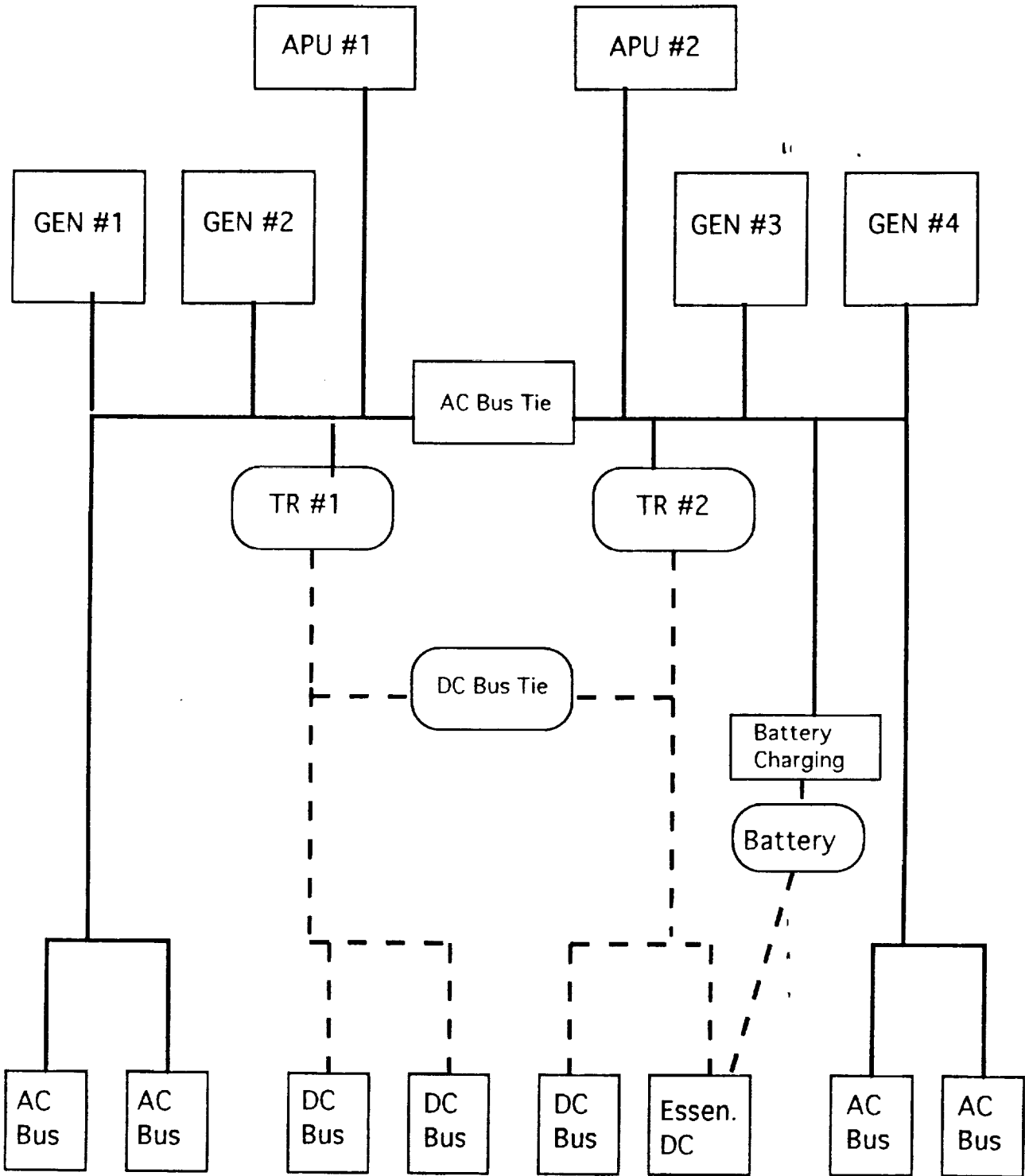

Figure VIII-2

### **3. Auxiliary Power Units**

Two auxiliary power units are incorporated into the Dumbo. They are located on either side, in the aircraft belly, aft of the nose gear and can be operated in flight and on the ground. The APU's provide electrical power, hydraulic power and bleed air. Using the main fuel supply, each APU has an intake on its respective side of the fuselage and exhausts out the bottom of the aircraft. The APU's are capable of being started with Dumbo's battery or by a hydraulic pressure accumulator in the U2 system.

### **4. Environmental Control**

The environmental control system pressurizes the aircraft and provides hot or cold air as desired. This is accomplished with compressor bleed air tapped off of all six engines, which is cooled under pressure through fuel heat exchangers, then expanded to provide cool air. Additional bleed air is mixed in directly to obtain the desired output temperature, and electrical blowers provide circulation. Separate temperature control is provided for the cabin air/pressurization, avionics cooling, and wind screen heating. Pressurization is maintained through the use of inflatable seals around the cabin doors, nose visor, etc. The seals are inflated with bleed air when the aircraft is in a "weight off wheels" condition. Any of the seals can be manually over ridden in flight. A set of liquid oxygen (LOX) bottles in the nose of the aircraft provide the flight crew with oxygen in the event the plane is either intentionally or unintentionally depressurized at altitude.

Both APU's are tied into the bleed air system and can provide air conditioning in addition to starting air for the main engines.

Engine, wing and wind screen deicing is accomplished with hot bleed air while pitot heating and prop fan deicing is accomplished electrically.

## 5. Fuel System

Dumbo is capable of holding 1.7 million pounds or 261,500 gallons of JP-4 (usable) within its main and canard wings. Each half of the canard holds a total of 12,200 gallons split between three fuel cells, for a total of 158,630 pounds of fuel in the canard. Each side of the main wing holds 118,500 gallons, divided between six fuel cells, for a total of 1,541,370 pounds of fuel in the main wing.

Each of the main wing fuel tanks is equipped with a transfer/boost pump capable of supplying all three engines on that wing. Each of the canard tanks is equipped with a transfer to aid in fuel transfer to the engines or main wing tanks and two transfer pumps at the canard wing's low point in case any one of the other transfer pumps fail. Fuel can be transferred from any one tank to another. This can be done automatically by the flight control computers to maintain a specific center of gravity for the aircraft or manually. All tanks can be refueled through single point refueling and to facilitate rapid refueling, four such locations have been incorporated in Dumbo, on either side of the fuselage aft of the canard wing, and underneath the main wing. All of the tanks are vented and nearly the entire fuel load can be dumped in flight. Fuel tank pressurization with bleed air assists with fuel transfer, feed and dumping.

Fuel system schematic is shown in VIII-3.

# Dumbo Fuel System

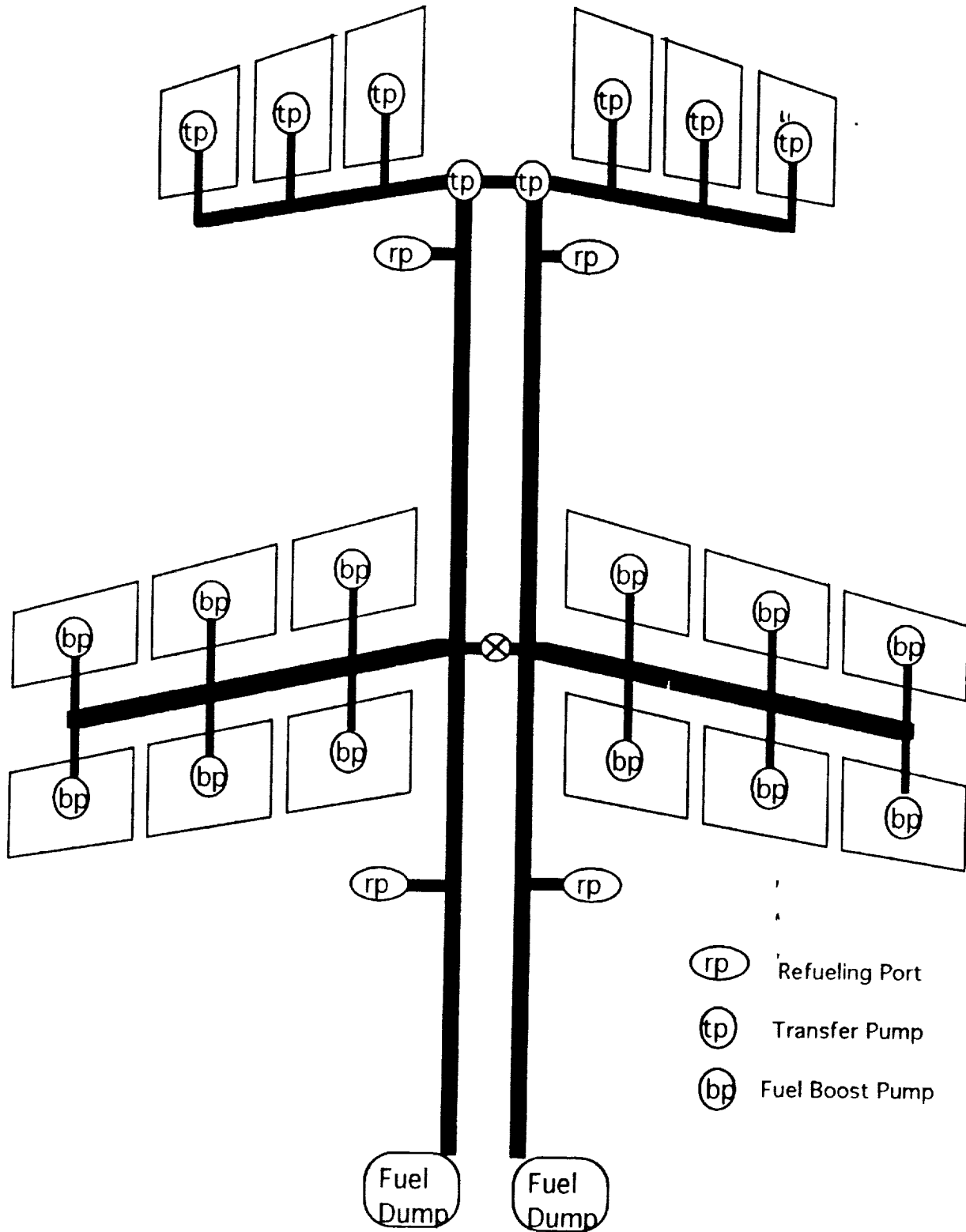

Figure VII-3

## 6. Cargo Provisions

Dumbo incorporates a main cargo deck 200 ft by 33 ft. It is 15 ft high in the center and tapers to 10.5 ft high at the sides. A hydraulically controlled nose visor and ramp provide access through the nose of the aircraft. Rear access to the main cargo deck is provided by a hydraulically controlled ramp and clam shell doors aft of the ramp. The aft ramp is capable of being opened in flight to permit aerial delivery of cargo or troops. Personnel access may also be obtained through personnel access doors located on either side of the fuselage, equipped with a boarding ladder. Removeable cargo handle roller strips can be placed in the floor to facilitate handling palletized cargo, or they may be removed to allow vehicles to drive up on the floor. The floor is stressed to permit M-1A tanks to drive on and park two abreast. The flooring is equipped with non-protruding anchor points at regular intervals. Standard 108 inch wide, type V airdrop pallets can be built up to any desired length and positioned in three rows.

The upper cargo deck is 20 ft wide and 185 ft long. The last 30 ft of the deck is hinged at the forward end, and can be hydraulically lowered to become a ramp to the upper deck. Typically, the upper deck cargo is off loaded through the cargo doors either side of the fuselage, forward and aft of the main wing. Personnel access doors at the aft end of the upper cargo deck can either be used as an aerial exit for paratroopers or with an appropriate ground accommodation ladder for passenger loading. The upper cargo deck is ten feet high except where the main wing carry through reduces clearance to five and one half feet. The entire upper deck can be rigged with jump seats to carry approximately 500 personnel. No provision is incorporated within the aircraft

to provide emergency oxygen. Emergency oxygen will be available in the removeable troop seats.

Hydraulic power from the U2 system, and electrical power run the length of both cargo decks and can be tapped to power cargo handling and ejection systems. Additionally, a data bus into the main aircraft computer can be accessed to give the computer control over the ejection of airborne cargo deliveries.

### **C. SURVIVABILITY**

The mission of the Dumbo Global Transport does not dictate that a concerted effort be made to include survivability in the design. However, because this is a military transport, vulnerability reduction was included. The Dumbo "kill tree" is shown in Figure VIII-4.

The most likely threat to the Dumbo is the long range air launched semi-active homing missile with a high explosive fragmentation warhead. The aircraft fuel system is the most vulnerable area with nearly 25,000 square feet of surface in the canard and main wing. Damage will most likely be caused by ballistic impact, penetration, hydraulic ram and combustion.

To counter the damage processes, the fuel tanks are self-sealing to penetration by 2 1/2 gram fragments (.7 cm). An On board Inert Gas Generating System (OBIGGS) is incorporated to prevent combustion. All tanks have backing board to protect against hydraulic ram, and there is a linear fire extinguishing system for dry bays.

The remaining vulnerability enhancement features were added through redundancy with separation mainly due to the complexity and size of the transport. These include: six engines, two fiber optic flight control paths, four

# DUMBO KILL TREE

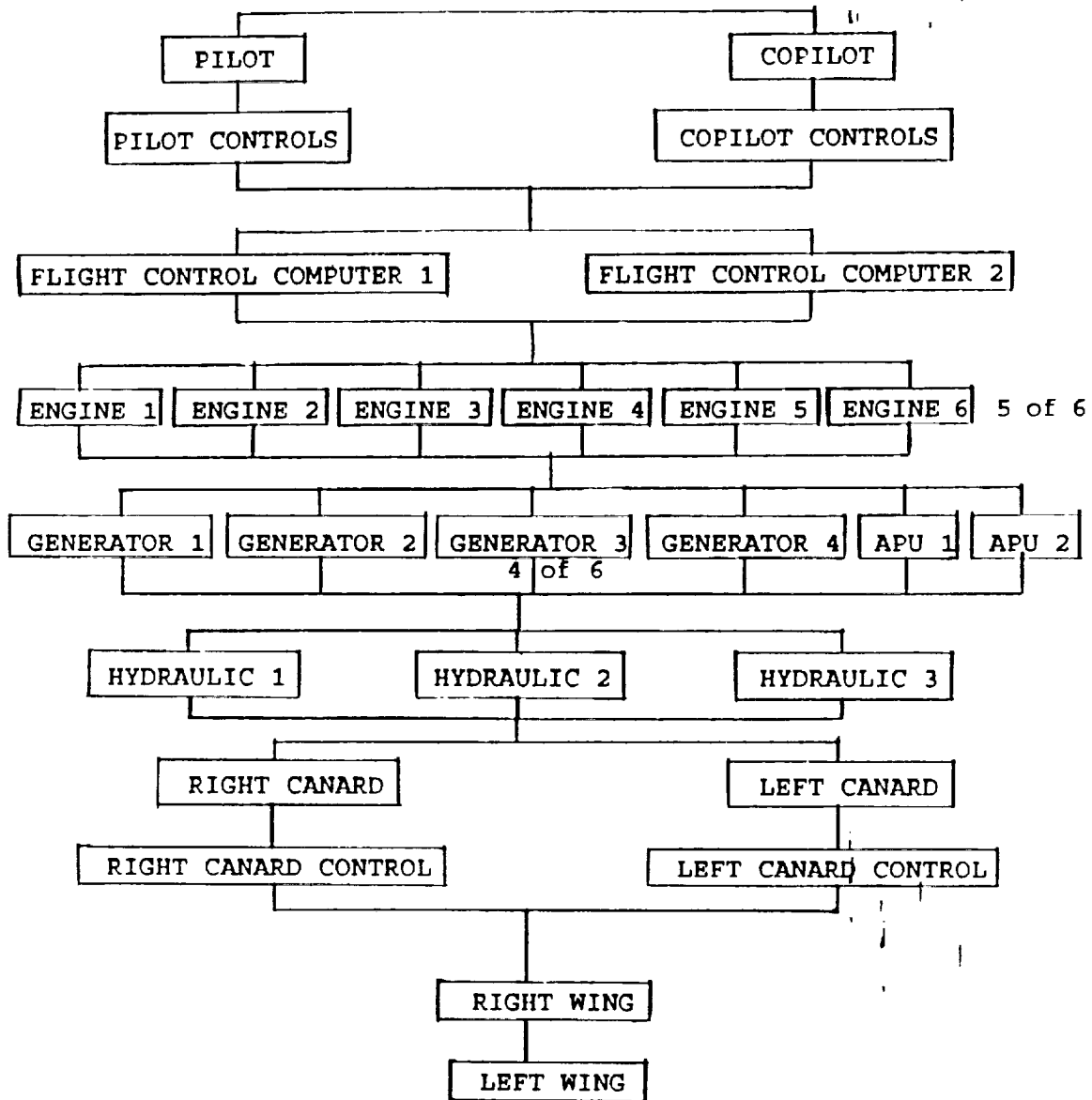

Figure VIII-4

electrical generators, two auxiliary power units and six hydraulic pumps to power three hydraulic systems. Any two of the hydraulic pumps are able to meet the demand of the aircraft. To do this, the system operates at 5000 psi, which beneficially reduces hydraulic line size, actuator size and reservoir size.

The flight control system uses two flight control computers. The system controls surface movement and hydraulic actuator operation. It is capable of shutting off hydraulic fluid to damaged actuators and servos, and re-configuring control surfaces. The computer also incorporates hydraulic level sensors to warn of low levels. The computers also control fuel to the six engines. Only 2 of which are needed for a safe landing after 1.2 million pounds of fuel burn/dump.

The electrical system is capable of functioning with only two generators. The APU's are able to power the electrical and hydraulic systems (utility). Due to its design, the only single point kill is destruction of the cockpit.

Susceptibility reduction is accomplished only through reduction of infrared signatures. This is accomplished through the diffusion of the hot exhaust gasses by bypass air of the counter-rotating fans.

## IX. PRODUCTION

### A. DEVELOPMENT, TEST AND PRODUCTION PHASES

To ensure operational capability, Flying Circus Design has outlined the acquisition process of the Dumbo heavy lifter transport into five phases, shown in Figure IX-1.

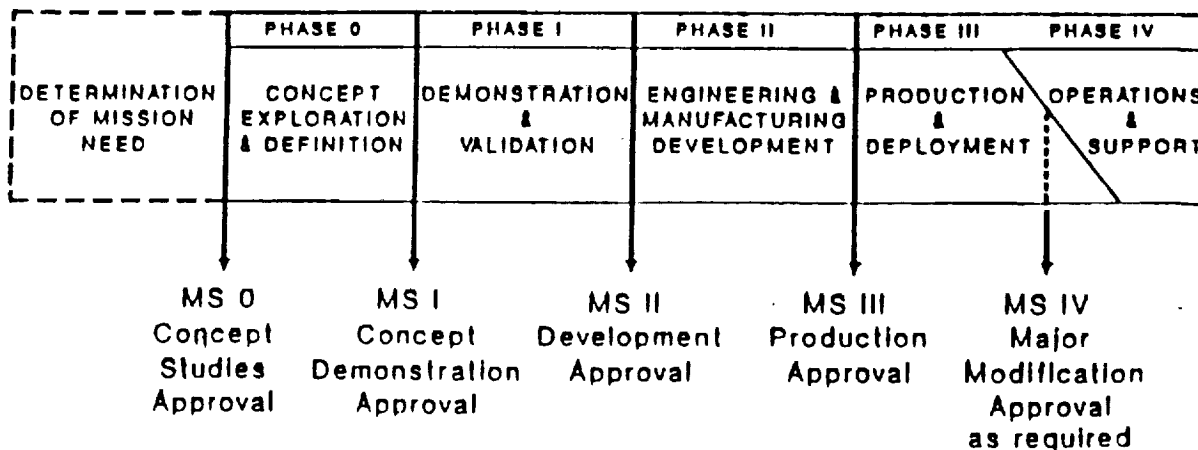

Figure IX-1

#### 1. Concept Exploration and Definition

This phase involved the exploration of alternatives to meet RFP requirements, definition of the most promising system concept, and the development of supporting analysis. This phase also included the development of a proposed acquisition strategy.

#### 2. Demonstration and Validation

The objectives of this phase are to better define the critical design characteristics and expected capabilities of the system, to demonstrate that the

technologies critical to the concept can be incorporated into the system design, and to establish a proposed Development Baseline that contains refined program cost, schedule and performance objectives. Test and Evaluation (T&E) during this phase will validate the approach and demonstrate that the aircraft/systems, through the fabrication and testing of an initial prototype can be built to meet operational needs. The Test & Evaluation Master Plan (TEMP), the controlling document that defines the T&E program, will establish the overall schedule of development and operational T&E in two phases as follows:

a. The Development Test and Evaluation (DT&E) phase will accomplish the following: assist in the design and development process, demonstrate that design risks have been minimized, estimate systems' military utility, evaluate compatibility/inter-operability with existing or planned equipment/systems, verify attainment of performance specifications/objectives, and provide assurance that the aircraft is ready for testing in an operational environment.

b. The Operational Test and Evaluation (OT&E) will be planned and conducted by Operational Test and Evaluation Force (OPTEVFOR). OT&E is divided into Initial OT&E (IOT&E), accomplished prior to the Production and Deployment decision, and Follow-on OT&E (FOT&E) conducted during the Production and Deployment Phase. FOT&E is to ensure initial production items meet operational effectiveness and suitability, identify needed changes, provide information on doctrine and personnel requirements and to provide data to support or verify adequacy of manuals and supporting plans.

At the completion of the demonstration and validation phase, development approval shall be gained.

### **3. Engineering and Manufacturing Development**

During this phase, Flying Circus Design will interact with the Department of Defense's Program Office to participate in the tradeoffs necessary to refine system and development specifications. Using one pre-production prototype, the Technical Evaluation (TECHEVAL) and Operational Evaluation (OPEVAL) will demonstrate that the aircraft/systems and support package of plans, procedures, spares and support equipment are ready for production and deployment to the fleet.

a. **TECHEVAL.** An equipment oriented evaluation based on technical parameters, duplicating the operating conditions and environment that will be encountered in OPEVAL and in operational use to ensure aircraft/systems are ready for OPEVAL. TECHEVAL results must demonstrate that: engineering is complete, all significant design problems and solutions have been identified, aircraft/system is functioning in an acceptable manner, all specified objectives and performance thresholds are met, and a high probability of successful performance in the OPEVAL exists.

b. **OPEVAL.** Conducted by OPTEVFOR, with the results, in combination with TECHEVAL and all prior testing, determining the effectiveness and suitability for operational use.

The primary goal of the engineering and manufacturing development phase is to acquire final production approval.

### **4. Production and Deployment**

Testing during this phase is to reveal minor discrepancies to be corrected. A Production Acceptance Test and Evaluation will ensure the production aircraft/systems satisfy contract specifications.

## 5. Operations and Support

This phase overlaps the deployment phase because support for new systems must start immediately upon fielding, although production could continue for many years.

### B. ORGANIZATIONAL STRUCTURE

Flying Circus Design is structured as depicted below.

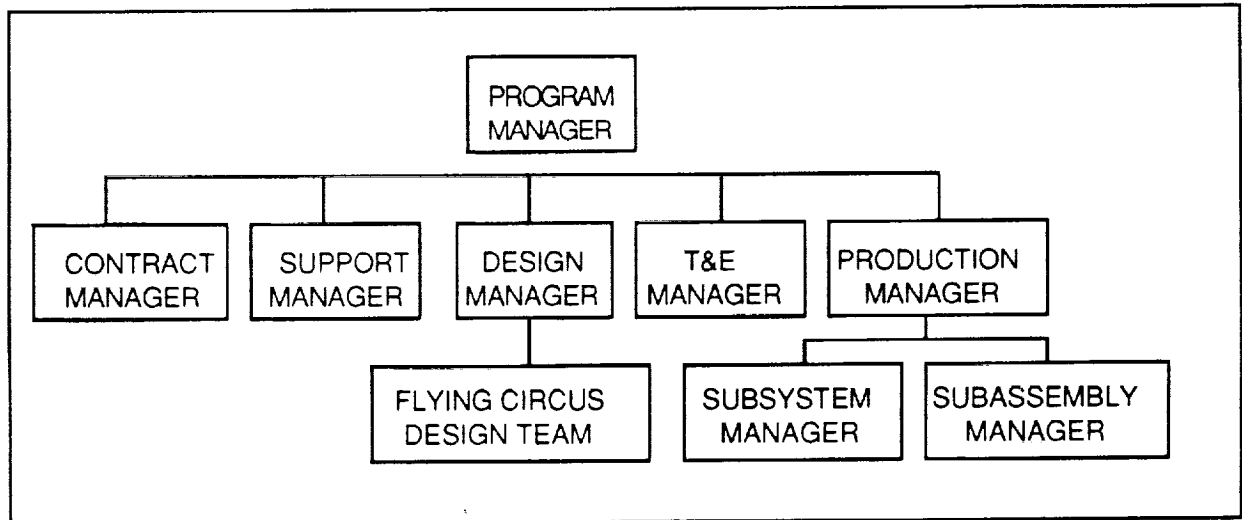

Figure IX-2

## X. COST AND QUALITY

### A. COST ESTIMATING RELATIONSHIPS

Cost analysis was completed using the Rand Cost Estimating relationship (CER) outlined in reference (21). The life cycle cost (LCC) was utilized to estimate the cost from the aircraft's "cradle to grave". This will include the development, test and evaluation phase (DT&E), the acquisition and the operations phase. Production quantities were established as one test and evaluation aircraft and 12 additional aircraft to service the world's transport needs for a total of 13. The total aircraft cost was divided into the three major categories listed above. The monetary amounts were adjusted to 1992 dollars by an economic escalation factor and the use of current "wrap rates" provided by aerospace facts and figures. These wrap rates which are hourly rates are shown as follows:

Engineering	\$66.48
Tooling	\$68.29
Quality Control	\$62.33
Manufacturing	\$56.36

Tables X-1 and X-2 provide a breakdown of the DT&E and Production costs.

## TOTAL DT&E COST

TOTAL DT&E COST	COST IN MILLIONS
Airframe Engineering	21,991.24
Development Support	454.96
Flight Test Aircraft	5053.30
Engines	36.27
Labor	1594.25
Mat'l & Equip	43.96
Tooling	3008.92
Quality Control	207.25
Flight Test Operations	<u>162.65</u>
	Subtotal 27662.15
	10% Adjustment <u>2766.21</u>
	Total DT&E Cost 30428.37
	= 30.428 Billion

Table X-1

## TOTAL PRODUCTION COST

PRODUCTION COST	COST IN MILLIONS
Engines	435.35
Manufacturing Labor	5862.11
Material and Equipment	314.72
Sustaining Equipment	34658.45
Tooling	4682.70
Quality Control	<u>762.06</u>
	Subtotal 46715.39
	10 % Adjustment <u>4671.54</u>
	Total Production Cost 51386.93
	= 51.4 Billion

Table X-2

These calculations represent a unit cost of 6.29 billion dollars per copy. Of course if it is deemed necessary to produce more aircraft to meet future transport needs, this unit cost will decrease significantly.

A cost analysis would not be complete without examining operation and maintenance costs. Table X-3 is provided to examine these costs. It utilizes the cost analysis procedure outlined in reference ( 21 ).

## OPERATION AND MAINTENANCE COSTS

Crew Ratio	1.5
Flight Hrs per Year per Aircraft	1000.0
Maintenance Man Hrs per Flight Hr.	30.0
Average Fuel Burned per Flight Hr.	7200.0
<hr/>	
Yearly Fuel Costs	93.6 M
Yearly Maintenance Costs	15.6 M
Yearly Crew Costs	4.7 M
<hr/>	
Total Yearly Operating Cost	113.9 M
<hr/>	
Total Operations and Maintenance costs (over 20 year service life)	2.28 B

Table X-3

### B. QUALITY

The primary tool used by the design team to establish priorities and define goals for each phase of the design process was the House of Quality. In the early stages of design, the team developed the first House of Quality to decide where priorities would be with relation to the RFP and how the specific requirements interrelated with aircraft performance parameters (Figures X-4,5 and 6). Next, the individual requirements were ranked according to their relative importance. The design team ranked weight as the number one priority and range as the second. These decisions influenced every area of the design throughout the



House of Quality for Product Characteristics

A/C CHARACTERISTICS	Relative Importance	Product Characteristics											
		Camber	Thickness t/c	Engine Type	Flap Choices	Fuel Tank Design	Composites	Wing Sweep	Aspect Ratio	Dihedral	Tires	High Strength Metals	Span
Wto	3	-	-	+	-	+	+	-	+	-	+	-	
L/D max	6	+	+	-	+	-	+	+	-	-	+	-	
CLmax	7	+	+	-	+	-	-	+	-	-	-	-	
W/S	8	-	-	-	-	+	-	-	-	-	+	-	
T/W	5	-	-	+	+	-	+	-	-	-	+	-	
Cdo	4	-	-	+	-	-	+	-	-	-	-	-	
Fuel Weight	2	-	-	-	-	-	+	+	-	-	+	-	
SFC	7	+	+	+	+	-	+	-	-	-	-	-	
Landing Gear	9	-	-	-	-	-	-	-	-	+	+	-	

Table X-5

02

House of Quality for Product Characteristics

Product Characteristics	Relative Importance	Production Control							
		Fasteners	Skin Tolerance	System Integration	Tooling	Testing	Comp Production	Reliability	Existing Tech.
Camber	9	-	-		-		-		-
Thickness t/c	10	-			-		+		+
Engine Type	1	-		+			+		-
Flap Choices	6		-				+	+	
Fuel Tank Design	2	-	-	-	+		+		
Composites	4							+	+
Wing Sweep	7	-	-		+		+		
Aspect Ratio	8						+		
Dihedral	11	-					+		
Tires	12			-				-	+
High Strength Metals	5		+		-	-	-	+	+
Span	3	-	-		-	-	+	-	-

Table X-6

## XI. SUMMARY

### A. SUMMARY

The design of this transport aircraft has evolved through two iterations. The next step involves multiple iterations in all design areas. Performance, structures, and propulsion require the most attention. The main source of difficulty in designing an aircraft to meet the given RFP requirements was finding data on aircraft of similar size to compare critical parameters.

It was clear that for this type of aircraft, weight is the most dominant factor in the design process. Burning fuel to carry fuel was indeed realized. Finally, the wing root loading problem would require extensive analysis for both peak and vibrational loading.

The Dumbo aircraft met or exceeded all RFP requirements.

## LIST OF REFERENCES

1. Aerospace Engineering, Vol. 3, no. 3, Sept 1983, *Advanced Propellers: Updated Evaluation Techniques*.
2. *Aerospace Facts and Figures, 1990-1991*.
3. Allen, David, Haisler, Walter, *Introduction to Aerospace Structural Analysis*, Wiley Books, 1985.
4. Anderson, John D., Jr., *Fundamentals of Aerodynamics, Second Edition*, McGraw-Hill, 1991.
5. Anderson, John D., Jr., *Introduction to Flight, Third Edition*, New York, 1989.
6. Aviation Week and Space Technology, 16 Mar 1992, *U.S. Gas Turbine Engines*.
7. Ball, Robert E., *The Fundamentals of Aircraft Combat Survivability Analysis and Design*, AIAA Education Series, American Institute of Aeronautics and Astronautics, Inc., 1985.
8. Brahney, James H., *Is the Unducted Fan Tomorrow's Subsonic Engine?*, Aerospace Engineering, Vol 5, No. 2, Feb 1985.
9. Coming, Gerald, *Supersonic and Subsonic, CTOL and VTOL, Airplane Design*, College Park, MD, 1976.
10. Currey, Norman S., *Aircraft Landing Gear Design: Principles and Practices*, American Institute of Aeronautics and Astronautics, Inc., 1988.
11. Etkin, *Dynamics of Flight, Stability and Control*, John Wiley and Sons, 1959.
12. Federal Aviation Regulations Part 25, *Air Worthiness Standards: Transport Aircraft*.
13. Garrard, Wilford, *The Lockheed C-5 Case Study in Aircraft Design*, New York, 1961.

14. Holt, Daniel J., *Prop Fan Engine Designs Examined*, Aerospace Engineering, Vol. 6, No. 2, Feb 1986.
15. Holt, Daniel J., *Will Prop Fans Require Gear Boxes*, Aerospace Engineering, Vol. 5, No. 2.
16. Levenson, G. S., *Cost Estimating Relationship for Aircraft Airframes*, Rand Report R-761-PR, Rand Corp., Santa Monica, CA, Dec 1971.
17. Martin, C. L., *Taguchi's Parameter Design Optimization Method Applied to Aircraft systems*, Georgia Institute of Technology.
18. McDonnell Douglas Flight Control Division, *USAF Stability and Control DATCOM*, St.Louis, 1976.
19. Meriam, J.L., Kraige, L.G., *Engineering Mechanics Dynamics*, Wiley Books, 1986.
20. Nelson, R.C., *Flight Stability and Automatic Control*, McGraw-Hill Book Co., New York, 1989.
21. Nicolai, Leland M., *Fundamentals of Aircraft Design*, San Jose, CA, 1984.
22. Propfan Parametric Data Package #SP04A80, *Aerodynamics and Acoustics Ten Blade Configuration*, October 1986.
23. Raymer D.P., *Aircraft Design: A Conceptual Approach*, American Institute of Aeronautics and Astronautics, Inc., Washington, D.C. 1989.
24. Roskam J., *Airplane Design*, Parts 1-8, Roskam Aviation & Engineering Corp., Ottawa, Kansas, 1986.
25. Stuart, Alan R., *The Leading Edge All UDF Special "Why the UDF?"*, The Leading Edge General Electric Company Aircraft Engine Business Group, Fall 1986.
26. Torenbeek, Egbert, *Synthesis of Subsonic Airplane Design*, Delft University Press, 1990.
27. Van Dyke, Milton, D., *National Advisory Committee For Aeronautics*, Technical Note 2670 (NACA TN2670), Mar 1952.

28. Mattingly, Jack D. et al., *Aircraft Engine Design*, American Institute of Aeronautics and Astronautics, New York, 1987.

### MILITARY REFERENCES

A. MIL-F-8785C, *Flying Qualities of Piloted Aircraft*, Military Specifications.

B. MIL-STD-8861.

